

Onset of Nucleate Boiling and Onset of Fully Developed Subcooled Boiling Using Pressure Transducers Signals Spectral Analysis

Alfredo José Alvim de Castro

Eduardo Maprelian

Daniel Kao Sun Ting

Instituto de Pesquisas Energéticas e Nucleares (IPEN)

Diretoria de Reatores

Caixa Postal 11049

05422-970 São Paulo, SP. Brazil

ajcastro@net.ipen.br

The experimental technique used for detection of subcooled boiling through analysis of the fluctuation contained in pressure transducer signals is presented. This work was partly conducted at the Institut für Kerntechnik und zertörungsfreie Prüfverfahren von Hannover (IKPH, Germany) in a thermal-hydraulic circuit with one electrically heated rod with annular geometry test section. Piezoresistive pressure sensors are used for onset of nucleate boiling (ONB) and onset of fully developed boiling (OFDB) detection using spectral analysis/ signal correlation techniques. Experimental results are interpreted by phenomenological analysis of these two points and compared with existing correlation. The results allow us to conclude that this technique is adequate for the detection and monitoring of the ONB and OFDB.

Keywords: *Subcooled boiling, spectral analysis, induced vibrations, experiment*

Introduction

The optimization of heat exchangers, steam generators and nuclear reactors has the common objectives of minimizing flaws occurrence with increasing thermal efficiency and power densities thus reducing costs. These equipment are extensively used in process and power plants and increasing efficiency and durability will certainly represent an important capital and energy saving for the modern industry competitiveness.

Considering the above objectives, the operation in a partially developed subcooled boiling regime is an important condition to be pursued in heat transfer processes when high heat fluxes and/or small transfer areas are present. In this region, located between the onset of nucleate boiling (ONB) and the onset of fully developed boiling (OFDB), significant increase in the heat transfer coefficient is obtained when compared to the single-phase convection values. The significant increase in the pressure drop and in the void fraction found in the fully developed boiling regime is not present neither.

Another important aspect related to the operation in this regime is that it is safer as far as occurrence of critical heat flux (CHF) is considered since generally speaking CHF will occur after the points of ONB and OFDB.

Therefore, the proper knowledge and determination of these two points in the subcooled boiling regime is very important in the optimization and monitoring of thermal systems and components.

The method of spectral analysis of pressure transducers signals applied to the detection of two-phase flows characteristics presents among other advantages, as an excellent option for the detection, monitoring and also, to develop correlation for the ONB and OFDB points to optimize heat exchangers design. In this method, dynamic pressure sensors detect the pressure waves caused by the bubble collapse and their signals are processed using spectral analysis techniques.

In this present work, the method is verified by phenomenological interpretation of these two points. An important and clarifying comparison with the existing experimental correlation in the literature for the determination of ONB and OFDB, is also presented.

ONB and OFDB Phenomenological Description

It should be pointed out that the main differences between the definitions of ONB and OFDB presented by different authors are not phenomenological in nature but instead, they are basically

semantical. In this paper, the differences will not be discussed, but rather, it will be proposed a set of definitions as illustrated in the [Fig. \(1\)](#) below (Collier, 1996).

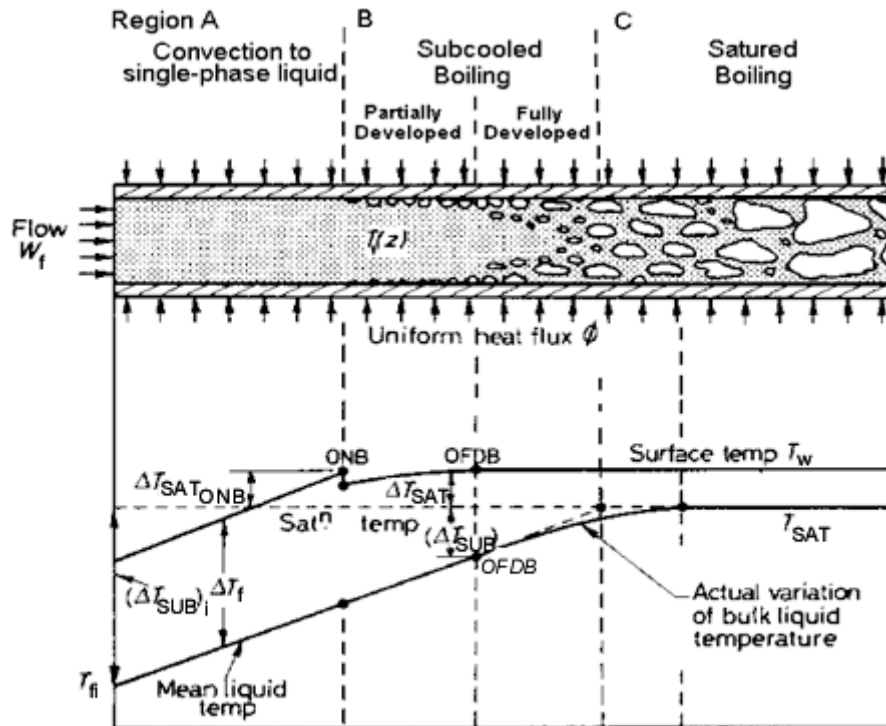

Figure 1. Schematic Representation of the Subcooled Boiling Regimen.

In the subcooled regime, the ONB is characterized by the formation of the first bubbles at the heated wall. This occurs when the wall reaches a certain degree of superheating sufficient for nucleation of bubbles. Depending on the degree of subcooling of the coolant, these bubbles condense and collapse. The greater the subcooling, smaller will be the bubble radius and lifetime. The condensation and collapse of the bubbles generate pressure waves in the flow accompanied by acoustic noise and structural vibration.

After the ONB follows the so-called partially developed boiling (PDB) as shown in [Fig. \(1\)](#). In this region the heat exchange capacity is greatly increased without significant increase in the void fraction.

The OFDB point is characterized by the net vapor generation, or in others words, not necessarily all the bubbles that detach from the heated surface will collapse inside the bulk flow. Under this condition, the pressure waves are significantly reduced and consequently the

noise and vibrations are also reduced. This sharp reduction in noise and vibration levels can be used for the detection of this point.

Beyond this point, the fully developed boiling (FDB) regime is established when the heat transfer is further enhanced by predominantly boiling mechanisms rather than convective heat transfer. In this region one can observe significant increase in pressure drop and void fraction.

One of the advantages of using pressure pulses analysis for the detection of subcooled boiling characteristics points is that it allows for a direct identification of the formation and collapsing of bubbles.

Single Rod Experimental Setup

A diagram of the experimental circuit used for the one-rod test section is shown in [Fig. 2](#). This experimental circuit was assembled and run at IKPH (Alvim et al, 1991), (Alvim and Ting, 1998), (Martens, 1987). This circuit can be divided into two parts: (A) is the feedwater section and (B) is the test section. Part (A) is constituted by a centrifuge pump, two air cooled heat exchangers, a pressurizer, a deairator, control valves, two bypasses and an air circulator. Part (B) is composed by the test section, the electrical supply and the sensors with their electronic processing system .

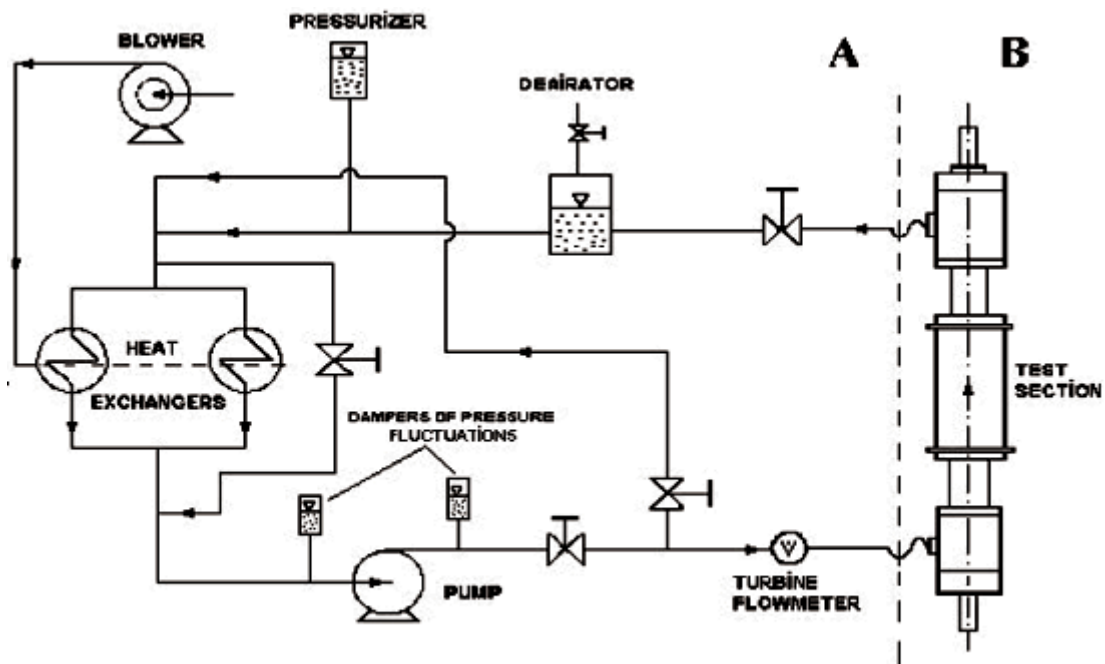

Figure 2. Experimental Loop for Subcooled Boiling - Flow Diagram.

The test section ([Fig. 3](#)) has a lower entrance plenum and an upper exit plenum, both made with aluminum. The main test channel is composed by several polycarbonate parts totaling 680 mm active length with 20 mm internal diameter with components for sensors positioning and flow visualization. The central heated rod has 11.5 mm diameter and an active length of 680 mm simulating PWR fuel rod. The heating is indirect controlled by a variable direct current 20 kVA transformer. The test section is connected to the feedwater section by flexible pipes to eliminate vibration transfer from the feedwater circuit, which might affect subcooled boiling induced vibration. To avoid corrosion and deposits and to improve reproducibility, demineralized water was used.

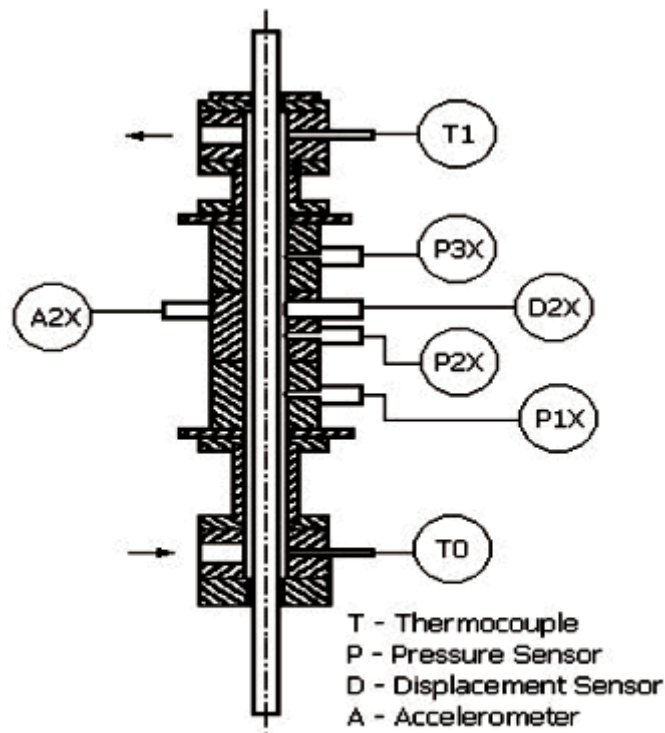

Figure 3. Single Heated Rod Annular.

Data Acquisition and Processing

To control and monitoring of the circuit during the experiments, the following operational parameters are measured: fluid temperature at the entrance and the exit of the test section, voltage and current through the heated rod and the flow rate through the test section.

The detection of subcooled boiling occurrence is done by measuring the pressure fluctuations at selected points along the channel. In order to separate other sources of vibration and to get better monitoring of boiling, some additional dynamic sensors are positioned to measure absolute displacement of the rod and test section acceleration.

The pressure fluctuations are obtained with four pressure minitransducers type Kulite XTM-190-50. Two of these pressure sensors named P2X and P2Y are installed in the middle (half-length) of the section oriented 90 degree apart defining the X and Y directions. The other two sensors are oriented in the X direction but one (P3X) is installed 100 mm above and another one (P1X) is installed 100 mm below. The heated rod displacement is measured using two inductive displacement sensors type Reutlinger WSG-69 positioned in the middle plane (D2X and D2Y), 90 degrees apart in the X and Y directions. To measure the vibration of the entire test section, a triaxial accelerometer type Kulite TGY-600-100 is used and placed at the outer surface on the half-length plane (A2X-Y-Z).

The data acquisition system is based on a HP21MX computer which receives the signals recorded analogically on tape. Before being recorded the signals are amplified to a maximum range of 1.5 volts and filtered to the frequency range of interest, which is 10 to 600 Hz.

The signal processing by Fast Fourier Transform (FFT) is also performed in the computer. The calculation of the Power Spectrum Density, Cross Correlation and Coherence are performed by a special program named FOURI. The signal recording time was adjusted in order to obtain 12,5% as maximum statistic error in frequency domain.

Experimental Results - ONB and OFDB Identification

As mentioned above, the ONB and OFDB are intimately related to the rate of bubble collapse, either in the beginning (ONB) or when a sharp reduction occurs (OFDB). The rate of bubble implosions can be detected by measuring the pressure pulses associated.

The experimental results here presented, refers to fixed conditions of pressure of 1,2 bar and average velocity in the test section of 1,5 m/s, for several inlet subcoolings, with or without heat flux in the rod.

The most significant experimental results for the analysis of the subcooled boiling regime are the power spectrum density (PSD) which is the signal power density in the frequency domain and the signal amplitude, or the signal pressure in the time domain, both

obtained by detecting the pressure pulses using dynamic sensors as described before.

The [Fig.4](#) present these results for the pressure transducer P2X for subcoolings of 77,5 and 45 K at the test section entrance.



Figure 4. Pressure Sensor P2X Signal in Frequency and Time Domain - ONB Condition.

The 77,5 K inlet subcooling condition correspond to the no heating condition, where one can identify two peaks in the power spectrum which are associated with the centrifuge pump and to standing waves resonance. Therefore, this condition is assumed as the reference for the single-phase regime (without boiling).

Fixing the heat flux in the rod at a constant and uniform value of 55 W/cm^2 , no significant changes are observed in the PSD curve from no heating condition inlet subcooling (77,5 K) up to values lower than 45 K. Further decrease in the inlet subcooling, by increasing the inlet temperature, will cause a sharp increase in the PSD and the occurrence of peaks in the signal amplitude, at the 45 K subcooling condition. These increases are associated with the onset of bubble collapses and indicate therefore the point of onset of nucleate boiling (ONB).

On the other hand, the [Fig. 5](#) shows the P2X power spectrum and amplitude curves for inlet subcoolings of 18,5 K, 16,5 K, and 14,2 K. From inlet subcoolings below 18,5 K a reduction in the PSD associated with the characteristic pulses is observed, as well as in their frequencies. These reductions are more pronounced in the 14,2

K condition where no significant characteristic pulses are observed and in time domain the signal loses its periodic behavior with the amplitude returning to levels near the no boiling conditions. These results shows a great decrease in the bubbles collapse rate indicating therefore, that the onset of fully developed boiling (OFDB) has been reached.

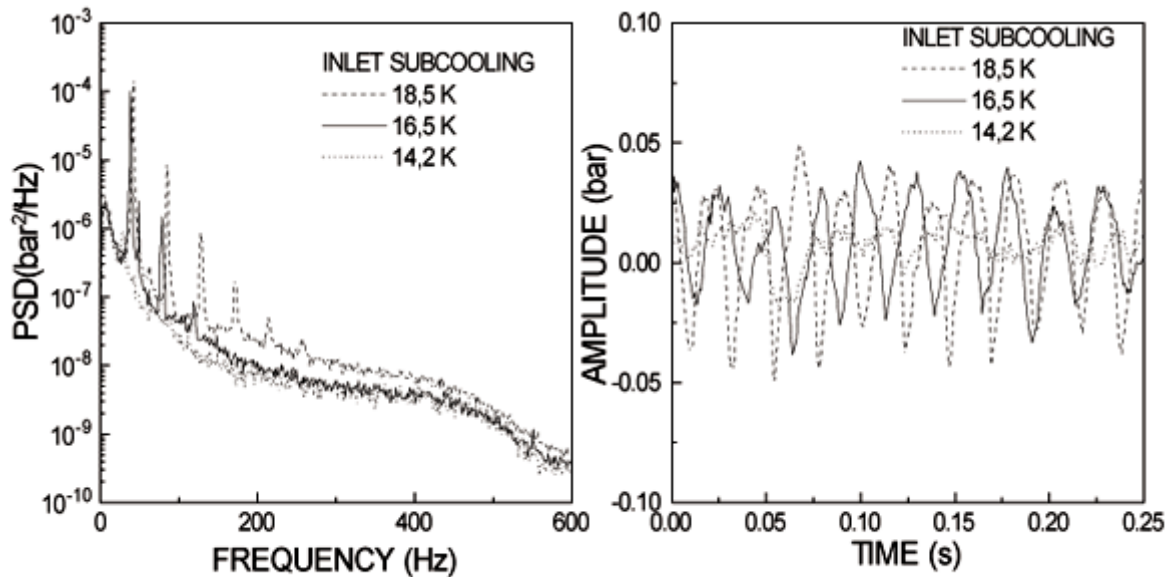

Figure 5. Pressure Sensor P2X Signal in Frequency and Time Domain. OFDB Condition.

Other very important curve to the subcooled flow boiling phenomenological analysis is the pressure pulses flux energy curve (Fig. 6), obtained through the integration of the PSD curve for several inlet subcoolings.

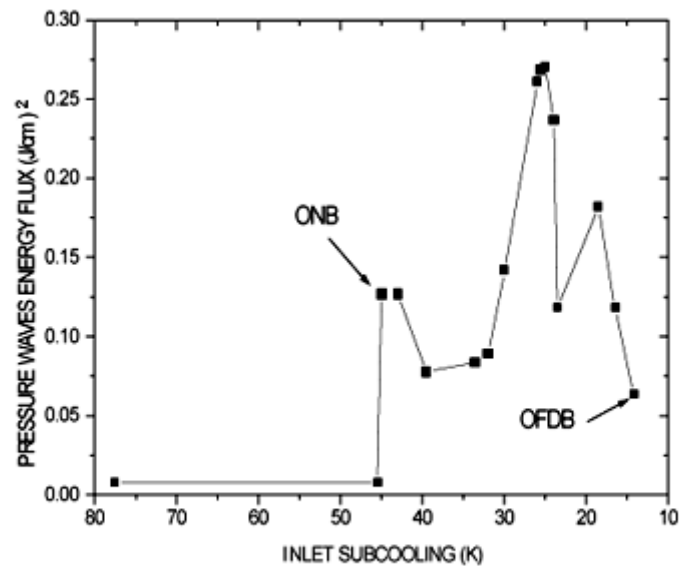

Figure 6. Pressure Waves Energy Flux versus Inlet Subcooling in the Pressure Sensor P2X.

From this curve analysis we can observe that:

- the flux energy in the single-phase region is very lower than in the PDB region;
- in the 45 K inlet subcooling condition occurs a sharp increase in the energy flux, corresponding to the boiling collapse pressure pulses and therefore indicates the ONB point;
- in the regions near 25 K and 18,5 K inlet subcoolings occur two energy flux peaks, due to the resonance in the test section;
- from inlet subcoolings below 18,5 K, a clear reduction in the energy flux is observed more specifically in the 14,2 K condition where the flux value nears the single-phase condition.

Comparison with Correlation

In this section, the conditions identified as the ONB as well as the OFDB are compared with empirical correlation available in the literature.

Several analytical models and empirical correlation have been developed for the prediction of these two important operational points. Below, the most applicable ones for these present test conditions are presented.

ONB Calculation

Among the various correlation available in the literature, the Bergles & Rohsenow (1964), Eq. (1), was selected since its range of validity is applicable for the cases being analyzed in this work.

$$(\Delta T_{SAT})_{ONB} = 0,556 \left(\frac{f_{ONB}}{1082 \cdot p^{1,156}} \right)^{0,463 \cdot p^{0,0234}} \quad (1)$$

where $(\Delta T_{SAT})_{ONB}$ is the wall superheat necessary to cause nucleation in ° C, ϕ_{ONB} is the surface heat flux to cause boiling in MW/m² and p is the system pressure in bar. This equation is applicable for a pressure range from 1 to 138 bar.

Yin's correlation (1993), Eq. (2) which range of validity is not available and Thom's correlation (1965), Eq. (3) which pressure range of 51,7 to 68 bar is above the 1,2 bar used in our experiments, will also be used to compare with the data from cases 1 and 2.

$$(\Delta T_{SAT})_{ONB} = 7,195 \cdot \phi_{ONB} \cdot p^{1,82} \cdot \gamma^{-0,072} \quad (2)$$

where γ is the subcooled boiling relative location, which is the P2X sensor relative position of 0,5.

$$\Delta T_{SAT} = 2265 (\phi_{ONB})^{0,5} \cdot \exp\left(\frac{-P}{87}\right) \quad (3)$$

To calculate the wall temperature under the experimentally determined ONB conditions (45 K inlet subcooling condition in [Fig. 4](#)) at the P2X sensor position, Dittus-Boelter correlation modified for film temperature properties (Holman, 1983) and Gnielinski correlation (1976) were used for evaluation of the single phase heat transfer coefficient (h_{fo}):

Dittus-Boelter Correlation Modified for Film Temperature Properties

$$N_u = 0,023 \cdot R_e^{0,8} \cdot P_r^{0,4} \quad (4)$$

where N_u , R_e and P_r are, respectively, the Nusselt, Reynolds and Prandtl numbers, and with

$$T_{film} = \frac{T_{wall} + T_{bulk}}{2} \quad (5)$$

where T_{film} , T_{wall} and T_{bulk} are the film, wall and bulk temperatures.

Gnielinski Correlation

$$Nu = \frac{f/8 \cdot (Re - 1000) P_r}{1 + 12.7 \sqrt{f/8} (P_r^{2/3} - 1)} \left[1 + \left(\frac{d}{L} \right)^{2/3} \right] 0.86 \left(\frac{d_i}{d_o} \right)^{-0.16} \left(\frac{P_r}{P_{rw}} \right) \quad (6)$$

where (d/L) is the diameter to length ratio, (d_i/d_o) the internal to external diameters of the annulus ratio, P_{rw} the Prandtl number for wall's properties and f the friction factor for turbulent flow

$$f = (1.82 \cdot \log_{10} Re - 1.64)^{-2} \quad (7)$$

The comparison between the wall temperature at the ONB position predicted by the three empirical correlation with those calculated from the experimental data and Dittus-Boelter for film temperature properties and Gnielinski's correlation are presented in [Table 1](#).

Table 1. Comparison between ONB Wall Temperatures (Estimated and Experimental).

ONB Temperature (°C)				
Estimated with Correlation			Calculated from Experimental Data	
B&R	Yin	Thom	Dittus-Boelter _{film}	Gnielinski
113.9	110.0	120.8	114.0	112.0

These results show a good agreement between the Bergles & Rohsenow's and Yin's values with the experimental values for the ONB wall temperature and a reasonable agreement for the Thom's correlation.

OFDB Calculation

For the predictions of the OFDB point it was selected the Saha and Zuber (1974) and the Ünal (1975) correlation and the Griffith (1958)

criterion. As indicated below, these equations determine the subcooling in the fluid temperature at the OFDB point ($\Delta T_{OFDB} = T_{SAT} - T_f$).

Saha and Zuber Correlation

$$\Delta T_{OFDB} = \frac{1}{0.0065} \cdot \frac{\phi}{Gc_{pf}} \quad \text{for } P_e = \frac{GD_h c_{pf}}{k_f} > 70.000 \quad (8)$$

$$\Delta T_{OFDB} = \frac{1}{455} \times \frac{\phi D_h}{k_f} \quad \text{for } P_e \leq 70,000 \quad (9)$$

where P_e is the Peclet number, D_h is the hydraulic diameter in meters, c_{pf} is the specific heat of liquid phase in (MW/kg°C), G is the mass velocity in (kg/m²s), k_f is the thermal conductivity of the liquid in (MW/m s°C) and ϕ is the heat flux in (MW/m²)

Ünal's Correlation

$$\Delta T_{OFDB} = \frac{\phi}{h_{fo}} \left[1 - \left(\frac{\Delta T_{OFDB}}{\Delta T_F} \right)^3 \right] \quad (10)$$

where h_{fo} is the single phase heat transfer coefficient calculated from the Dittus-Boelter correlation (DB), the Dittus-Boelter correlation for film temperature properties (DB_f) and the Gnielinski correlation (Gn.), ΔT_{OFDB} and ΔT_F are the superheating of the liquid for the OFDB point and pool boiling (or fully developed boiling) regime respectively, and with

$$\left(\frac{\Delta T_{OFDB}}{\Delta T_F} \right) \cong 0.92 \quad \text{for } v \geq 0.45 \text{ m/s} \quad (11a)$$

$$\left(\frac{\Delta T_{OFDB}}{\Delta T_F} \right) \cong 0.96 \quad \text{for } v < 0.45 \text{ m/s} \quad (11b)$$

Griffith Criterion

Griffith's criteria is expressed by

$$\phi_{OFDB} = 5 \cdot \phi_{SPL}, \quad \text{resulting that } \Delta T_{OFDB} = \frac{\phi}{5h_{fo}} \quad (12)$$

with h_{fo} calculated from Gnielinski correlation.

Table 2 presents the fluid subcooling at the OFDB condition estimated by the above mentioned correlation in the P2X sensor position and their respective inlet subcoolings, compare with the experimentally measured inlet subcooling, identified as the OFDB condition in section 5. In Fig. 7, these same results are plotted on a relative basis for comparison.

Table 2. Comparison of Subcooling at OFDB between Estimated and Measured.

Subcooling at OFDB Condition in P2X Sensor (°C)						
Position	Estimated					Measured
	Saha & Zuber	Ünal/DB	Ünal/DB _r	Ünal/Gn.	Griffith	
P2X	13,7	12,3	10,8	10,4	9,4	—
INLET	≤ 18,3	≤ 16,9	≤ 15,4	≤ 15,0	≤ 14,0	14,2

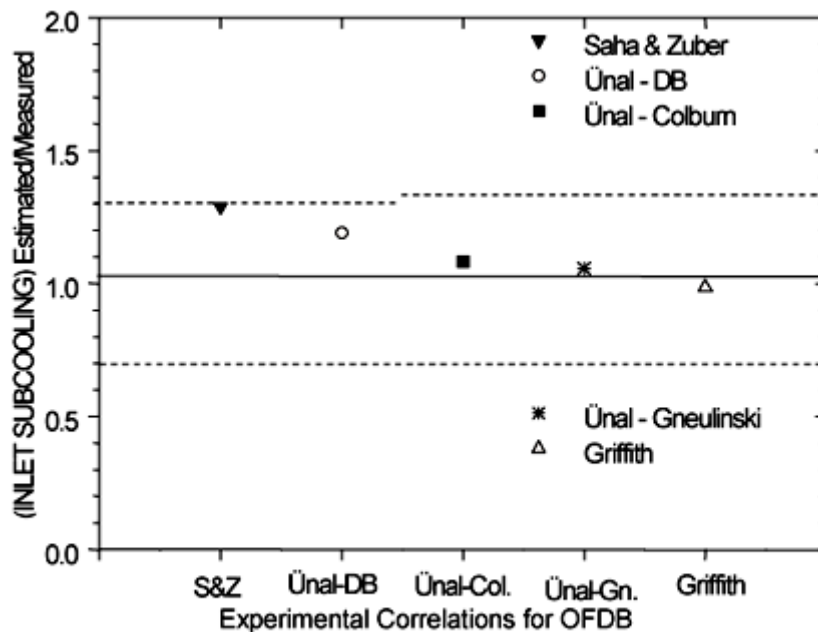

Figure 7. Estimated to Measured Inlet Subcooling Ratio for the OFDB Condition.

From these results one can observe a reasonable agreement between the estimated values and the experimental results of subcooling at the OFDB point with deviations lower than 29 %.

Conclusions

The main objective of this work is to develop and demonstrate the feasibility of monitoring and detecting the ONB and OFDB subcooled boiling conditions using pressure transducers and spectral analysis of their signals.

From the results of the comparison between the experimental data and the expected phenomenological behavior, the ONB and OFDB points were clearly identified by the strong relationship of the ONB and OFDB with the sharp increase and the great reduction in the level of pressure pulses to the rate of bubbles collapses.

The comparison using empirical correlation for the calculation of ONB and OFDB indicated a reasonable to good agreement between the estimated values and the experimental ones, with deviation always lower than 29%.

One can therefore conclude that the method of spectral analysis of pressure transducers signals, presented in this work, is adequate for the detection and monitoring of the ONB and OFDB under the range of operational conditions studied.

References

Alvim de Castro, A .J., Martens, V., Stegemann, D., 1991, Análise de vibrações em barras excitadas por ebulição subresfriada, ENFIR, Atibaia, Brazil. [[Links](#)]

Alvim de Castro, A .J., Ting, D. K. S., 1998, Subcooled boiling detection using pressure transducers signal spectral analysis, Maintenance and Reliability Conference - MARCON-98. University of Tennessee. [[Links](#)]

Bergles, A.E. and Rohsenow, W.M., 1964, The determination of forced-convection surface boiling heat transfer, Transactions ASME, series C, 86. [[Links](#)]

Bucher, B., "Beitrag zum Siedebeginn beim Unterkühlten Sieden mit Zwangskonvektion", Promotionsarbeit, Hannover Universität, Hannover, 1979. [[Links](#)]

Celata G. P. et al, 1997, Experimental evaluation of the onset of subcooled flow boiling at high liquid velocity and subcooling, Int. J. Heat Mass Transfer. Vol 40 no 12. [[Links](#)]

Collier, J. G, Thome, J. R., 1996, Convective boiling and condensation, 3rd ed. Oxford Clarendon Press, New York. [[Links](#)]

Gnielinski, V., 1976, New equations for heat and mass transfer in turbulent pipe and channel, flow, Int. Chem. Eng. vol. 16, pp 359-368. [[Links](#)]

Griffith P. et al, 1958, Void volumes in subcooled boiling systems, ASME-AIChE Heat Transfer Conference, paper 58-HT-19, Chicago. [[Links](#)]

Holman, J. P., 1983, Transferência de Calor, McGraw-Hill do Brasil, São Paulo. [[Links](#)]

Martens, V., 1987, Untersuchung der schwingungsanregung von wärmetauscherrohren durch mantelseitiges unterkühltes sieden", Promotionsarbeit, Hannover Universität, Hannover. [[Links](#)]

Saha, P., Zuber, N., 1974, Point of net vapor generation and vapor void fraction in subcooled boiling, Proceedings of Fifth International Heat Transfer Conference, Vol. 4, pp175-179. [[Links](#)]

Thom, J. R. S., Walker, W. M., Reisting, G. F. S., 1965, Boiling in subcooled water during flow in heated tubes or annuli, Symposium on Boiling Heat Transfer In Steam Generating Units and Heat Exchangers, Manchester, IMechE, London. [[Links](#)]

Ünal, H. C., 1975, Determination of the initial point of net vapor generation in flow boiling systems, Int. J. Heat and Mass Transfer Vol 18 pp 1095-1099. [[Links](#)]

Yin, S. T., 1993, Up-date on heat-transfer package for high heat flux components cooling, Proceedings of the 3rd Specialists'Workshop on High Heat Flux Components Thermal-Hydraulics, Cadarache. [[Links](#)]

Paper originally presented at the 15th Brazilian Congress of Mechanical Engineering (XV COBEM), São Paulo, November 22-26, 1999.

COBEM Editors: R. G. dos Santos, M. H. Robert, A. C. Dannwart, J. R. B. Cruz.

Associate Editor: J. R. F. Arruda.