

Monitoring and fault detection: a comparative study using computational intelligence techniques

Monitoração e detecção de falhas: um estudo comparativo utilizando técnicas de inteligência computacional

DOI: 10.46814/lajdv6n1-002

Recebimento dos originais: 26/12/2024

Aceitação para publicação: 04/01/2024

Elaine Inacio Bueno

Doctorate in Nuclear Technology

Institution: Instituto Federal de São Paulo (IFSP)

Address: Rua Pedro Vicente, 625, Canindé, São Paulo – SP, CEP: 01109-010

E-mail: ebueno@ifsp.edu.br

Iraci Martinez Pereira

Doctorate in Nuclear Technology

Institution: Instituto de Pesquisas Energéticas e Nucleares (IPEN)

Address: Av. Prof. Lineu Prestes, 2242 - Cidade Universitária, São Paulo – SP, CEP: 05508-000

E-mail: martinez@ipen.br

ABSTRACT

In this work, two different Computational Intelligence Techniques were used to provide a comparative study by using Neural Networks and Neuro-fuzzy applied in Monitoring and Fault Detection in sensor of an experimental reactor. Both methodologies were developed and tested using a model composed by 9 variables: N2 (% power), T3 (pool water temperature), T4 (decay tank inlet temperature), T7 (primary loop outlet temperature), T8 (secondary loop inlet temperature), T9 (secondary loop outlet temperature), F1M3 (primary loop flowrate), F2M3 (secondary loop flow rate) and R1M3 (nuclear dose rate). It was used data from the first week experimental reactor IEA-R1 operation from October 2012 in both Monitoring Systems, which was divided in subsets in a following way: 60% for training, 20% for tests and 20% for validation. The results obtained using Neuro-fuzzy were better than the ones with Neural Networks.

Keywords: neural networks, fuzzy logic, neuro-fuzzy, ANFIS, modeling.

RESUMO

Neste trabalho, duas diferentes Técnicas de Inteligência Computacional foram usadas para fornecer um estudo comparativo utilizando Redes Neurais e Neuro-fuzzy aplicados em Monitoramento e Detecção de Falhas em sensores de um reator experimental. Ambas as metodologias foram desenvolvidas e testadas utilizando um modelo composto por 9 variáveis: N2 (% de potência), T3 (temperatura da água da piscina), T4 (temperatura de entrada do tanque de decaimento), T7 (temperatura de saída do circuito primário), T8 (temperatura de entrada do circuito secundário), T9 (temperatura de saída do circuito secundário), F1M3 (caudal do circuito primário), F2M3 (caudal do circuito secundário) e R1M3 (caudal de dose nuclear). Foram utilizados dados da primeira semana de operação experimental do reator IEA-R1 de outubro de 2012 em ambos os Sistemas de Monitoramento, que foram divididos em subconjuntos da seguinte forma: 60% para treinamento, 20% para testes e 20% para validação. Os resultados obtidos com os neuro-difusos foram melhores do que os obtidos com as Redes Neurais.

Palavras-chave: redes neurais, lógica difusa, neuro-difusa, ANFIS, modelagem.

1 INTRODUCTION

The interest in research and development of more robust methods on Monitoring and Fault Diagnosis have been encouraged because of the increasing demand on quality, reliability and safety in production processes. This interesting is justified due to complexity of some industrial processes, as chemical industries, power plants, and so on. In these processes, the interruption of the production due to some unexpected change can bring risk to the operator's security besides provoking economic losses, increasing the costs to repair some damaged equipment. Because of these two points, the economic losses and the operator's security, it becomes necessary to implement Monitoring and Diagnosis Systems [16] [12] [14] [6].

Nuclear power plants are complex system. There are a lot of variable numbers to be continuously observed in a nuclear power plant; moreover it is necessary to guarantee performance and safeness. During a fault the operators receive a lot of information through the instruments reading. Due to a lot of information in a short period of time, the operators are forced to take some decisions in stress conditions, so in some cases the fault diagnosis became difficult. Many techniques using Artificial Intelligence have been used in Monitoring and Fault Diagnosis with the purpose to help the nuclear power plants operators, including the Fuzzy Logic [13], Artificial Neural Networks (ANNs) [5] [1], the Group Method of Data Handling (GMDH) [3], Genetic Algorithms (AGs) [11] [5]. The uses of these techniques are justified because it is possible to model the process without using algebraic equations [8], by using only a database which contains the plant information.

The use of ANN is interesting because it can perform the correct input-output relationship for the given problem; This shortcoming prevents the ANN from providing expert knowledge about Monitoring and Fault Detection in heuristic terms which human prefer.

The problem of Monitoring and Fault Detection can be solved by incorporating the use of fuzzy logic and neural network (neurofuzzy). Fuzzy logic has the capability of transforming heuristic and linguistic terms into numerical values for use in complex machine computations by using fuzzy rules and membership functions [7]. For these reasons, fuzzy logic can be used to provide a general heuristic solution to a specific problem by using general heuristic knowledge about it.

The purpose of this work is to provide a comparative study by using Neural Networks and Neurofuzzy applied in Monitoring and Fault Detection in sensors of an experimental reactor.

2 ARTIFICIAL NEURAL NETWORK

An ANN is a massively parallel distributed processor made up of simple processing units, which has a natural propensity for storing experiential knowledge and making it available for use. The knowledge is acquired by the networks from its environment through a learning process which is basically responsible to adapt the synaptic weights to the stimulus received by the environment. The fundamental element of a neural network is a neuron, which has multiple inputs and a single output, as we can see in Figure 1. It is possible to identify three basic elements in a neuron: a set of synapses where a signal x_j at the input of synapse j connected to the neuron k is multiplied by the synaptic weight w_{kj} , an adder for summing the input signals, weighted by the respective synapses of the neuron; and an activation function for limiting the amplitude of the output of a neuron.

The neuron also includes an externally applied *bias*, denoted by b_k , which has the effect of increasing or lowering the net input of the activation function, depending on whether it is positive or negative, respectively [15].

Figure 1. Neuron model

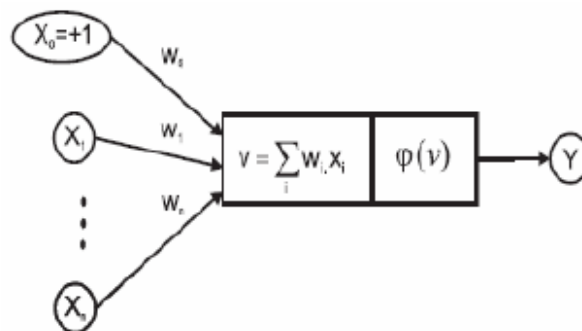

In this work, it was used the Multilayer Perceptron (MLP) neural network. In this kind of architecture, all neural signals propagate in the forward direction through each network layer from the input to the output layer. Every neuron in a layer receives its inputs from the neurons in its precedent layer and sends its output to the neurons in its subsequent layer. The training is performed using an error backpropagation algorithm, which involves a set of connecting weights, which are modified on the basis of a gradient descent method to minimize the difference between the desired output values and the output signals produced by the network, as shown in equation (1):

$$E = \frac{1}{2} \sum_{m=1}^m (y_{dj}(n) - y_j(n))^2 \quad (1)$$

where E : mean squared error; m : number of neurons in the output layer; yd_j : target output; y_j : actual output; n : number of interactions.

3 NEURO-FUZZY

Neuro-fuzzy is a combination of artificial neural networks and fuzzy logic. A neuro-fuzzy system is a fuzzy system that uses a learning algorithm derived from or inspired by neural network theory to determine its parameters (fuzzy sets and fuzzy rules) by processing data samples.

Fuzzy logic is a form of many-valued logic or probabilistic logic; it deals with reasoning that is approximate rather than fixed and exact. Compared to traditional binary sets (where variables may take on true or false values) fuzzy logic variables may have a truth value that ranges in degree between 0 and 1. Fuzzy logic has been extended to handle the concept of partial truth, where the truth value may range between completely true and completely false [9]. Furthermore, when linguistic variables are used, these degrees may be managed by specific functions.

The term "fuzzy logic" was introduced with the 1965 proposal of fuzzy set theory by Lotfi A. Zadeh [10][4]. Fuzzy logic has been applied to many fields, from control theory to artificial intelligence. Fuzzy logics however had been studied since the 1920s as infinite-valued logics notably by Łukasiewicz and Tarski [4].

Neuro-fuzzy was proposed by J. S. R. Jang. Neuro-fuzzy hybridization results in a hybrid intelligent system that synergizes these two techniques by combining the human-like reasoning style of fuzzy systems with the learning and connectionist structure of neural networks. Neuro-fuzzy hybridization is widely termed as Fuzzy Neural Network (FNN) or Neuro-Fuzzy System (NFS) in the literature. Neuro-fuzzy system (the more popular term is used henceforth) incorporates the human-like reasoning style of fuzzy systems through the use of fuzzy sets and a linguistic model consisting of a set of IF-THEN fuzzy rules. The main strength of neuro-fuzzy systems is that they are universal approximators with the ability to solicit interpretable IF-THEN rules.

4 IPEN IEA-R1 RESEARCH REACTOR

The IPEN nuclear research reactor IEA-R1 is a pool type reactor using water for the cooling and moderation functions and graphite and beryllium as reflector. Its first criticality was in September 16th, 1957. Since then, its nominal operation power was 2 MW. In 1997 a modernization process was performed to increase the power to 5 MW, in a full cycle operation time of 120 hours, in order to improve its radioisotope production capacity. Figure 2 shows a flowchart diagram of the Ipen nuclear research reactor IEA-R1.

Figure 2. IEA-R1 experimental reactor schematic diagram

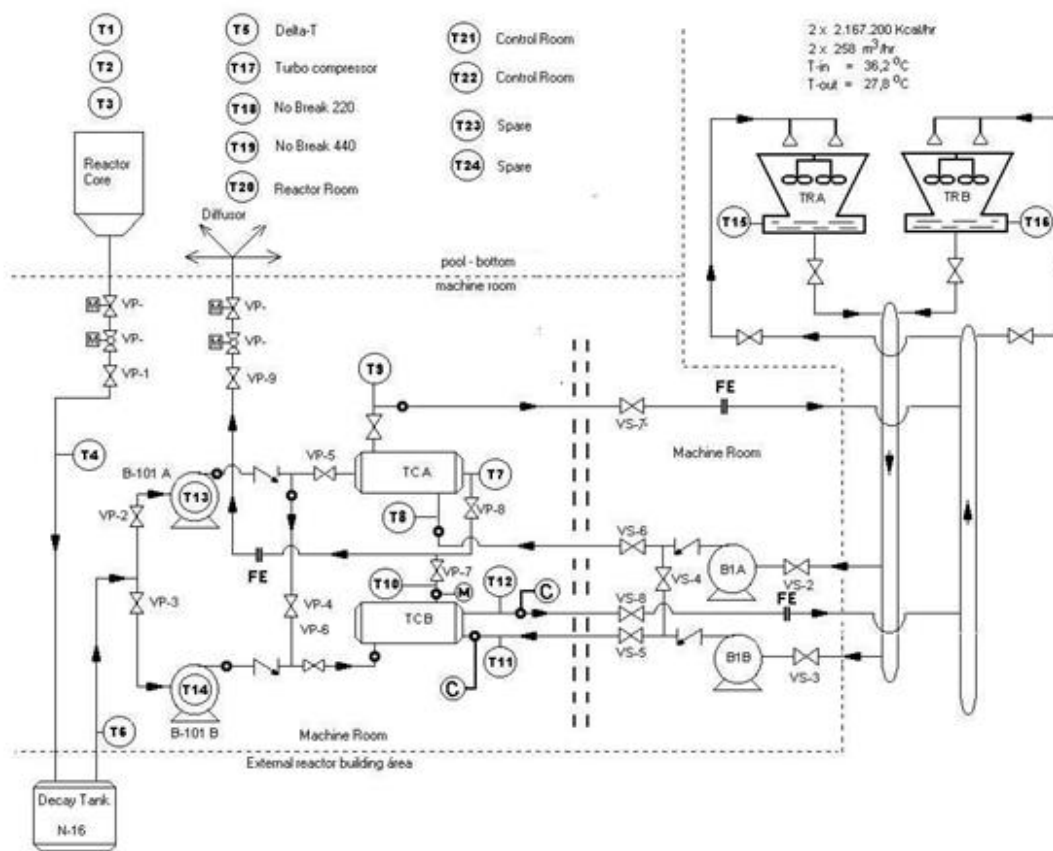

5 IEA-R1 DATA ACQUISITION SYSTEM (DAS)

The Ipen reactor Data Acquisition System monitors 58 operational variables, including temperature, flow, level, pressure, nuclear radiation, nuclear power and rod position (Table 1). The DAS performs the storage the temporal history of all process variables monitored and does not interfere with the reactor control.

Table 1. IEA-R1 DAS variables

Z1	Control rod position [0 a 1000 mm]
Z2-Z4	Safety rod position 1, 2 and 3[0 a 999 mm]
N2-N4	% power (safety channel 1, 2 and 3) [%]
N5	Logarithm Power (log channel) [%]
N6-N8	% power [%]
F1M3	Primary loop flowrate [gpm]
F2M3	Secondary loop flowrate [gpm]
C1-C2	Pool water conductivity [μ mho]
L1	Pool water level [%]
R1M3- R14M3	Nuclear dose rate [mR/h]
T1-T3	Pool water temperature [$^{\circ}$ C]
T4 and T6	Decay tank inlet and outlet temperature [$^{\circ}$ C]
T5	(T4-T3) [$^{\circ}$ C]
T7	Primary loop outlet temperature (heat exchanger A) [$^{\circ}$ C]
T8-T9	Secondary loop inlet and outlet temperature (heat exchanger A) [$^{\circ}$ C]
T10	Primary loop outlet temperature (heat exchanger B) [$^{\circ}$ C]
T11-T12	Secondary loop inlet and outlet temperature (heat exchanger B) [$^{\circ}$ C]
T13-T14	Housing pump B101-A and B102-A temperature [$^{\circ}$ C]
T15-T16	Cooling tower A and B temperature [$^{\circ}$ C]
T17	Housing turbo compressor temperature [$^{\circ}$ C]
T18-T19	NO-BREAK temperature –220V and 440V [$^{\circ}$ C]
T20-T24	Room temperature [$^{\circ}$ C]

6 MONITORING AND FAULT DETECTION SYSTEM

A Monitoring and Fault Detection system was developed using two different intelligent computational techniques: Neural Networks and Neuro-fuzzy.

These methodologies was developed and tested using a model composed by 9 variables: N2, T3, T4, T7, T8, T9, F1M3, F2M3 and R1M3, which were described in section V. This model was used previously in a Monitoring System [2].

Data from the 1st week experimental reactor IEA-R1 operation from October 2012 was used to perform both Monitoring Systems. The DAS performs the acquisitions at an interval of 30 seconds.

Database was divided in subsets in a following way: 60% for training, 20% for test and 20% for validation. This division was used in both Monitoring Systems.

The Monitoring and Fault Detection Systems use Neural Networks and Neuro-Fuzzy techniques to calculate each of one of the 9 variables estimative. These values are then compared with the actual variable value. For each one of the monitored variables it was calculated the percent error called residual.

The Neural Network used a Multilayer Perceptron Network (MLP) as architecture of neuron model. The MLP was composed by three layers: one input layer, one hidden layer and on output layer. The input layer is composed by 8 neurons and its activation function is linear; the hidden layer is composed by 10 neurons and its activation function is the hyperbolic tangents. The output layer is composed by a neuron that represents the output of the network.

The results obtained can be observed in Table 2.

Table 2. Results obtained by using Neural Network

Monitored variable	Residual (%)
N2	1,8624
T3	0,4136
T4	0,4836
T7	0,6154
T8	1,4659
T9	0,6967
F1M3	16,9914
F2M3	0,0760
R1M3	4,8926

Figure 3 shows the monitoring results in T3 variable (coolant temperature above the reactor core) using neural network.

Figure 3: Neural network result for Temperature T3 monitoring.

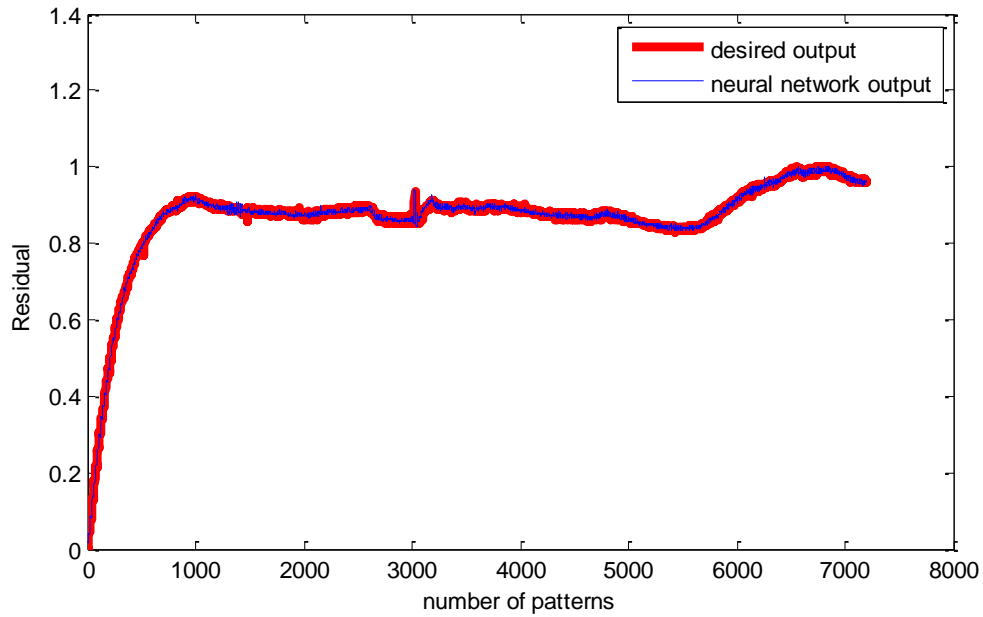

The monitoring result for F1M3 variable is showed in Figure 4. Although the residual has a value of almost 17%, this is caused more because this particular variable presents a great value of noise.

Figure 4: Neural network result for F1M3 monitoring.

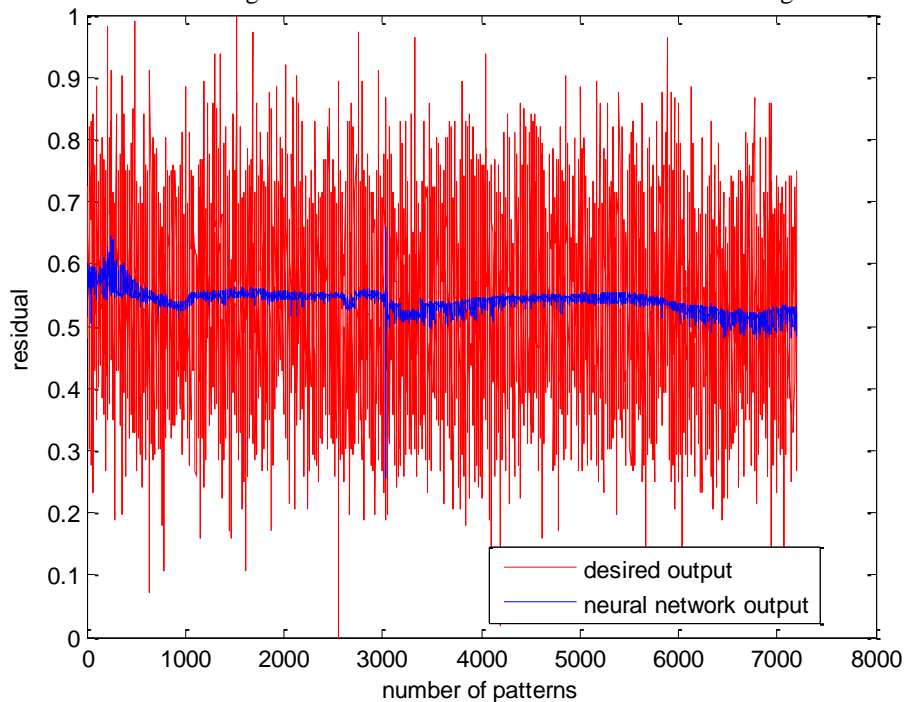

The Neuro-fuzzy System was built using the ANFIS Matlab which was found in Fuzzy Logic Toolbox [11]. Using a given input/output data set, the toolbox function anfis constructs a fuzzy inference system (FIS) whose membership function parameters are tuned (adjusted) using either a

backpropagation algorithm alone, or in combination with a least squares type of method. This allows your fuzzy systems to learn from the data they are modeling. The algorithm creates a fuzzy decision tree to classify the data into one of $2n$ (or pn) linear regression models to minimize the sum of squared errors (SSE) (2):

$$SSE = \sum e_j^2 \quad (2)$$

where:

e_j is the error between the desired and the actual output

This technique provides a method for the fuzzy modeling procedure to learn information about a data set, in order to compute the membership function parameters that best allow the associated fuzzy inference system to track the given input/output data.

Using this ANFIS Editor GUI we can:

- Load the data (training, tests and validate);
- Generate an initial FIS model;
- Choose the number of training epochs and the training error tolerance.
- Choose the FIS model parameter optimization method: backpropagation or a mixture of backpropagation and least squares (hybrid method).
- Train the FIS model by clicking the Train Now button. This training adjusts the membership function parameters
 - Plot the training (and/or checking data) error plot(s) in the plot region.
 - View the FIS model output versus the training, checking, or testing data output by clicking the Test Now button.

The Fuzzy Inference System uses Sub. Clustering, the optimization Method was Hybrid and the Neuro-fuzzy System was trained for 30 epochs.

Figure 5 shows the result for the temperature T3 monitoring.

Figure 5. Neuro-Fuzzy result for Temperature T3 monitoring

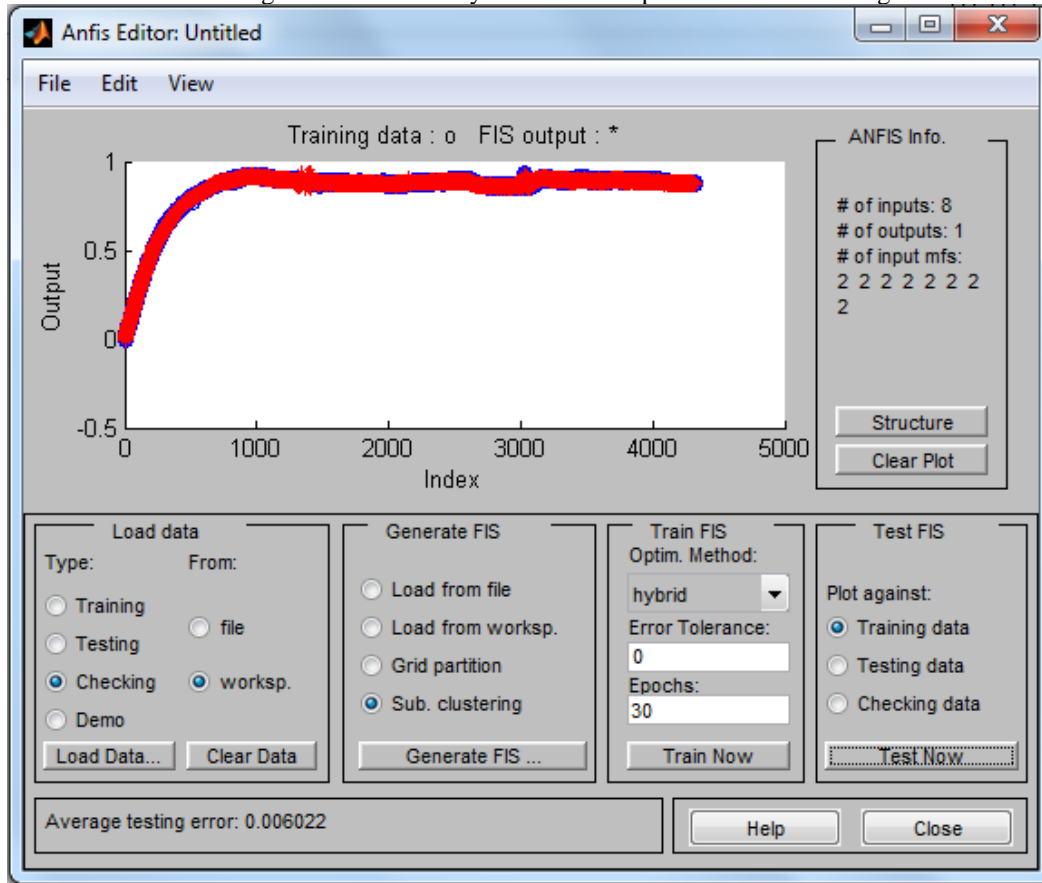

Table 3 presents the results for the variable monitoring using Neuro-Fuzzy technique.

Table 3. Results obtained by using Neuro-fuzzy

Monitored variable	Residual (ANFIS)
N2	0,044825
T3	0,006022
T4	0,007657
T7	0,007788
T8	0,013113
T9	0,009898
F1M3	0,12445
F2M3	0,11858
R1M3	0,090971

Figure 6 shows a comparison between the two techniques, showing a better result for the Neuro-Fuzzy.

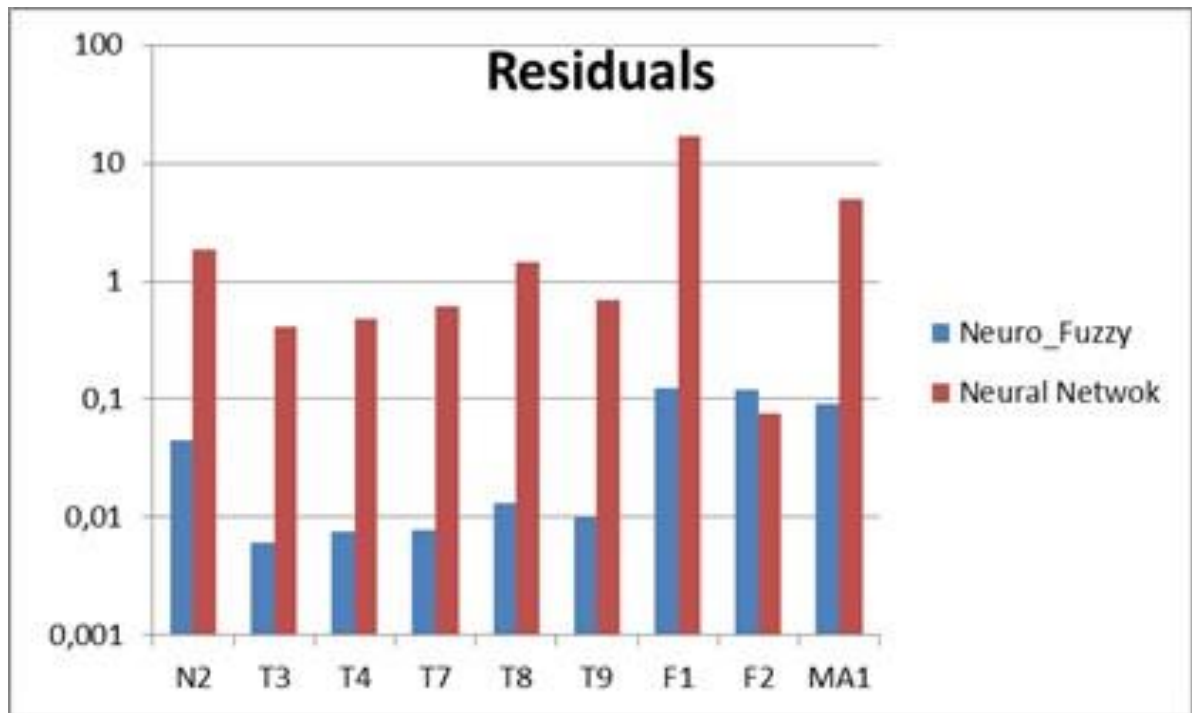

Figure 6. Neuro-Fuzzy and Neural Networks results

7 CONCLUSION

In this work two different computational intelligence techniques were used: Neural Networks and Neuro-fuzzy to develop a Monitoring and Fault Detection system. A set of nine variables were used from the IEA-R1 experimental nuclear reactor data acquisition system. The Neuro-Fuzzy technique showed strongly better results compared with Neural Network as we can see in Figure 6 and Table 3.

REFERENCES

- [1] B. SAMANTA. “Gear fault detection using Artificial Neural Networks and support vector machines with genetic algorithms”, *Mechanical Systems and Signal Processing*, vol. 18, n. 3, pp. 625-644, 2004.
- [2] E. I. BUENO. “Group Method of Data Handling e Redes Neurais na Monitoração e Detecção de Falhas em reatores nucleares”, Tese (Doutorado), Universidade de São Paulo-IPEN, 2011.
- [3] E. I. Bueno, I. M. Pereira, A. T. Silva. “Group method of data handling and neural networks applied in temperature sensors monitoring”, *International Journal of Nuclear Knowledge Management*, vol. 5, n. 3, 2011.
- [4] F. J. PELLETIER. “Review of metamathematics of fuzzy logics”, *The Bulletin of Symbolic Logic*, vol. 6, n. 3, pp. 342 – 346, 2000.
- [5] G. A. ROVITHAKIS, M. MANIADAKIS, M. ZERVAKIS. “A Hybrid Neural Network/Genetic Algorithm approach to optimizing feature extraction for signal validation”, *IEEE Transactions on Systems, Man, And Cybernetics – Part B: CYBERNETICS*, vol. 34, n. 1, pp. 695-703, 2004.
- [6] J. E. A. ECHENDU, H. ZHU. “Detecting changes in the condition of process instruments”, *IEEE Transactions on Instrumentation and Measurement*, vol. 43, n. 2, pp. 355-358, 1994.
- [7] J. E. TIMPERLY. “Incipient fault detection through neural RF monitoring of large rotating machines”, *IEEE Trans. Power App. And Syst.*, vol. 102, n. 3, 1983.
- [8] J. ZUPAN, M. NOVIC, I. RUISANCHEZ. “Kohonen and counterpropagation artificial neural networks in analytical chemistry”, *Chemometrics and Intelligent Laboratory Systems*, vol. 38, n. 1, pp. 1-23, 1997.
- [9] L. A. ZADEH. “Fuzzy Logic”, *Stanford Encyclopedia of Philosophy*, Stanford University, 2006-07-23, Retrieved 2008-09-30.
- [10] L. A. ZADEH. “Fuzzy Sets”, *Information and Control*, vol. 8, n. 3, pp. 338-353, 1965.
- [11] M. L. RAYMER, et. al. “Dimensionality reduction using Genetic Algorithms”, *IEEE Transactions on Evolutionary Computation*, vol. 4, n. 2, pp. 164-171, 2000.
- [12] P. H. SYDENHAM, R. THORN. “Strategies for sensor performance assessment”, *IEEE Instrumentation and Measurement Technology Conference Record*, pp. 353 – 358, 1993.
- [13] P. V. GOODE. “Using a Neural/Fuzzy System to extract heuristic knowledge of incipient faults in induction motors: Part I – Methodology”, *IEEE Transactions on Industrial Electronics*, vol. 42, n. 2, pp. 131-138, 1995.
- [14] R. N. CLARK. “Instrument fault detection”, *IEEE Transactions on Aerospace Electronic Systems*, vol. 14, pp. 456-465, 1978.
- [15] S. HAYKIN. “Neural Networks – A Comprehensive Foundation”, Prentice Hall, 1999.
- [16] Y. MAKI, K. A. LOPARO. “A Neural Network approach to fault detection and diagnosis in industrial processes”, *IEEE Transactions on Control System Technology*, vol. 5, n. 6, pp. 529-541, 1997.

[17] Matlab Fuzzy Logic Toolbox for use GUIs with MATLAB Version 5, The MATH WORKS Inc, MA, USA, 1997.