

Study of the Crystal Structure of the High Tc Superconductor Hg_{1-x}Re_xBa₂Ca₂Cu₃O_{8+δ} by Using EXAFS, XANES and XRD

Luis Gallego Martinez^{a*}, Jesualdo Luiz Rossi^a, Marcos Tadeu D'Azeredo Orlando^b,

Carlos Augusto Cardoso Passos^b, Hamilton Perez Soares Corrêa^c

^aMaterials Science and Technology Centre,

Nuclear and Energy Research Institute – IPEN, CNEN, 05508-900 São Paulo - SP, Brazil

^bFederal University of Espírito Santo – UFES, Vitória - ES, Brazil

^cFederal University of Mato Grosso do Sul – UFMS, Campo Grande - MS, Brazil

Received: March 21, 2007; Revised: April 22, 2008

Hg based superconducting ceramics present the highest critical temperatures ever reported, particularly the phase 1223 with the highest Tc so far obtained –135 K. However, these compounds are obtained by a complex synthesis route and suffer degradation at ambient atmosphere. This disadvantage may be overcome by doping with an appropriate amount of Re. Samples of nominal composition Hg_{0.82}Re_{0.18}Ba₂Ca₂Cu₃O_{8+δ} having different oxygen contents were studied by X ray absorption and diffraction techniques. Using XANES we determined the Re valence = +7 in an octahedral distorted coordination. We determined the distances of Re-O bonds (1.85 Å and 2.10 Å) by EXAFS. XRD Rietveld fits showed segregation of two superconducting phases with distinct lattice parameters. The main phase is associated with Hg, Re-1223 with higher oxygen content, and the secondary superconducting phase is related to undoped Hg-1223.

Keywords: high Tc superconductor, XRD, EXAFS, XANES, Rietveld

1. Introduction

Since the discovery of high Tc superconductors by Bednorz and Muller¹ in La-cuprate system, several other families of ceramic superconductors were produced. In 1993, Putilin et al.² obtained a new family, namely, HgBa₂Ca_{n-1}Cu_nO_y (n = 1,2,3...), which presented the highest Tc (134 K) ever reported. When exposed to ambient atmosphere this Hg-cuprate system loses its superconducting properties due to CO₂ contamination, however this problem has been overcome by partial substitution of mercury by rhenium³. Clearly the presence of Re increases the amount of oxygen in the HgO layer, because of its higher valence³. These additional oxygen atoms stabilize the mercury layer. Namely, samples with 18% nominal atomic Re content presented an improvement of the superconducting properties, such as the critical current density, when compared to HgBa₂Ca₂Cu₃O_y, Hg-1223 without Re³.

The crystal structure of Hg,Re-1223 has been intensively studied by some authors⁴ and discrepant results have been reported. For instance the term δ in the stoichiometry of oxygen - one of the most important parameters in all ceramic high Tc superconductors - is still matter of discussion⁴.

In this work we studied three different samples of Hg_{1-x}Re_xBa₂Ca₂Cu₃O_{8+δ} with 18% nominal content of Re and different oxygen contents, obtained by means of different oxidation treatments during the synthesis process. In order to study the crystal structure of the samples we employed different techniques such as X ray Absorption Near Edge Structure (XANES), Extended X ray Absorption Fine Structure (EXAFS) and X ray Diffraction (XRD) with application of Rietveld analysis in order to fully characterize the crystallography of the compounds. The techniques revealed to

be useful and complementary to one another allowing the determination of the valence of Re cations in the samples, Re-O coordination and bond lengths. These results were used as input to the Rietveld analysis of XRD data.

The resulting Rietveld fits show the segregation in two superconducting phases with slight different cell parameters and different contents of rhenium and oxygen, in addition to other minor residual phases due to the incomplete synthesis. The superconducting phases were classified as one main oxygen and rhenium rich phase and an additional rhenium free and oxygen poor phase.

2. Experimental

Three samples of Hg_{0.82}Re_{0.18}Ba₂Ca₂Cu₃O_{8.7+δ} with δ values equal to 0, 0.10 and 0.15, labeled as A, B and C, respectively, were prepared as described elsewhere⁴. Rietveld analysis of X ray diffraction (XRD) data was performed with the purpose of completing our previous study^{3,5}. The X ray diffraction measurements were carried out in conventional laboratory diffractometers as well as in the X ray Powder Diffraction beamline, D10B-XPD, of the Brazilian Synchrotron Light Laboratory (LNLS), located at Campinas, Brazil. Conventional XRD measurements employed Cu K_α radiation and the synchrotron measurements were performed also at an energy close to the rhenium L_{III} absorption edge, where the rhenium scattering factor is higher due to anomalous scattering. The spectra were measured from 2° to 122° in 2_θ with 0.01° step scan. The instrumental parameters were obtained from the fitting procedure applied to standard LaB₆ and Al₂O₃ samples (NIST-Standard Reference Materials) at each energy. Rietveld fits were performed using program GSAS⁶ with EXPGUI interface⁷.

*e-mail: lgallego@ipen.br

Absorption measurements were also made at the Brazilian Synchrotron Light Laboratory (LNLS) using the X ray absorption spectroscopy beamline D04B-XAS. The Re L_{III} absorption edge spectra at 10.535 keV were measured from 10.400 keV up to 11.400 keV, in 1 eV steps in the XANES region and 2.5 eV steps in the EXAFS region. The absorption data were analyzed using of the programs FEFF and FEFFIT^{8,9}

3. Results and Discussion

XANES study consisted in comparing the known valences of Re cations in elementary Re and two different rhenium oxides with the energy of its L_{III} absorption edges, in order to establish the calibration curve to be applied to the Re edge energy of the superconducting samples, thus inferring its valence in the compound. Figure 1a shows details of the top of Re absorption edges in the oxides ReO_2 , ReO_3 and in samples A, B and C of the compound. Figure 1b shows the values of valence versus edge displacement in elementary Re and in Re oxides. It allowed us to determine a linear calibration curve, which was used to estimate the valence of Re in the superconducting samples, as presented in Table 1.

The values of valence for the samples are in agreement with the one estimated by Chmaissem¹⁰ for a similar sample, using the Bond Valence Method, namely, 6.85¹¹.

As the intensity of X ray scattering by an atom is proportional to the square of its atomic number, the intensity of the X rays scattered by basal planes of Hg, Re superconductors is mainly determined by the heavy cations. Thus, the contribution of anions O^{2-} in the basal planes to XRD reflections is too small to be able to give information about its atomic positions, vibrations and occupations. In order to overcome this difficulty we employed EXAFS, a short range technique suitable to supplying information about the local coordination around the absorbing atom. The structural model for EXAFS

Table 1. Re valence in elementary and Re oxides and in the superconducting samples.

	Re	ReO_2	ReO_3	Sample A	Sample B	Sample C
Valence	0	+4	+6	+6.89	+6.93	+7.00

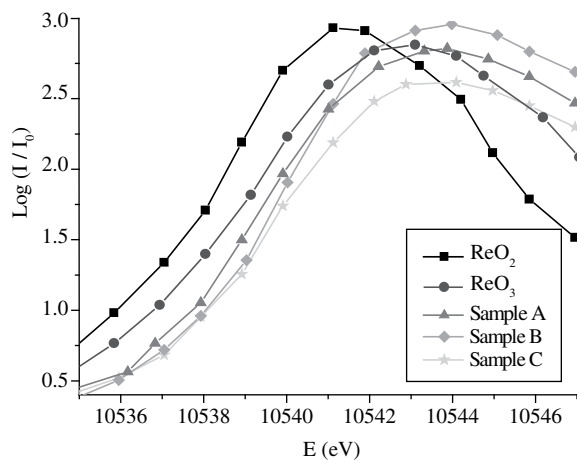

(a)

calculation was implemented by the programs ATOMS and FEFF^{8,9}, using the values of the cell parameters, the space group and a model for the atomic positions reported in literature^{4,5,10} as initial inputs. The analysis was carried out on the same spectra used for XANES, however using the far region above the absorption edge (from 30 to 1000 eV above the edge). For EXAFS analysis we employed the program ATOMS⁹ for calculating the scattering paths, the program AUTOBK for background corrections and the program FEFF to calculate scattering amplitude, angles and phases for each scattering path. The program FEFFIT performed the adjustment between the calculated and measured data. The results for the two first coordination shells are shown in Table 2.

Re-O bond lengths indicate a distorted octahedral coordination with C_{4v} symmetry, similar to that found in ReO_3 under isostatic pressure⁴. In order to confirm the reliability of the EXAFS results we applied the Bond-Valence Method¹¹ to calculate the valences for the bond distances obtained and the results were very similar to those presented in Table 1, showing the coherence of the method.

In the Rietveld analysis we at first found difficulties in adjusting the profile function using only one superconducting phase, due to a strong asymmetry in the 001 reflection, as shown in Figure 2a, b and c. However, when using high resolution Synchrotron diffraction it was observed that that asymmetry was actually a convolution of two very close peaks, as can be seen in Figure 2d.

The double peak led us to propose the co-existence of two superconducting phases with a small difference in parameter c. In order to take it into account we introduced a second superconducting phase together with other residual phases, as shown in Table 3.

Table 2. Results from the EXAFS analysis for the first and second coordination shells: O_{eq} are the equatorial oxygens (in the basal plane) and O_{ap} are the apical ones (in the 001 direction)⁴.

	Sample A	Sample B	Sample C
$\sigma^2 O_{eq}$ (\AA^2)	0.0155 (9)	0.0137 (17)	0.0157 (13)
dist. Re - O_{eq} (\AA)	1.85 (5)	1.83 (9)	1.87 (9)
$\sigma^2 O_{ap}$ (\AA^2)	0.0201 (20)	0.0165 (17)	0.0204 (34)
dist. Re - O_{ap} (\AA)	2.09 (10)	2.15 (2)	2.00 (14)

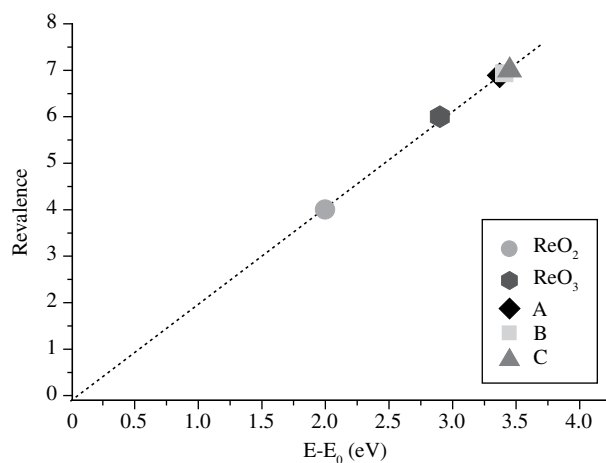

(b)

Figure 1. a) details of the Re L_{III} absorption edges in ReO_2 , ReO_3 oxides and in the samples A, B and C; and b) valences of Re in the samples of the Hg,Re-1223, B and C, determined from the L_{III} e absorption edge displacements.

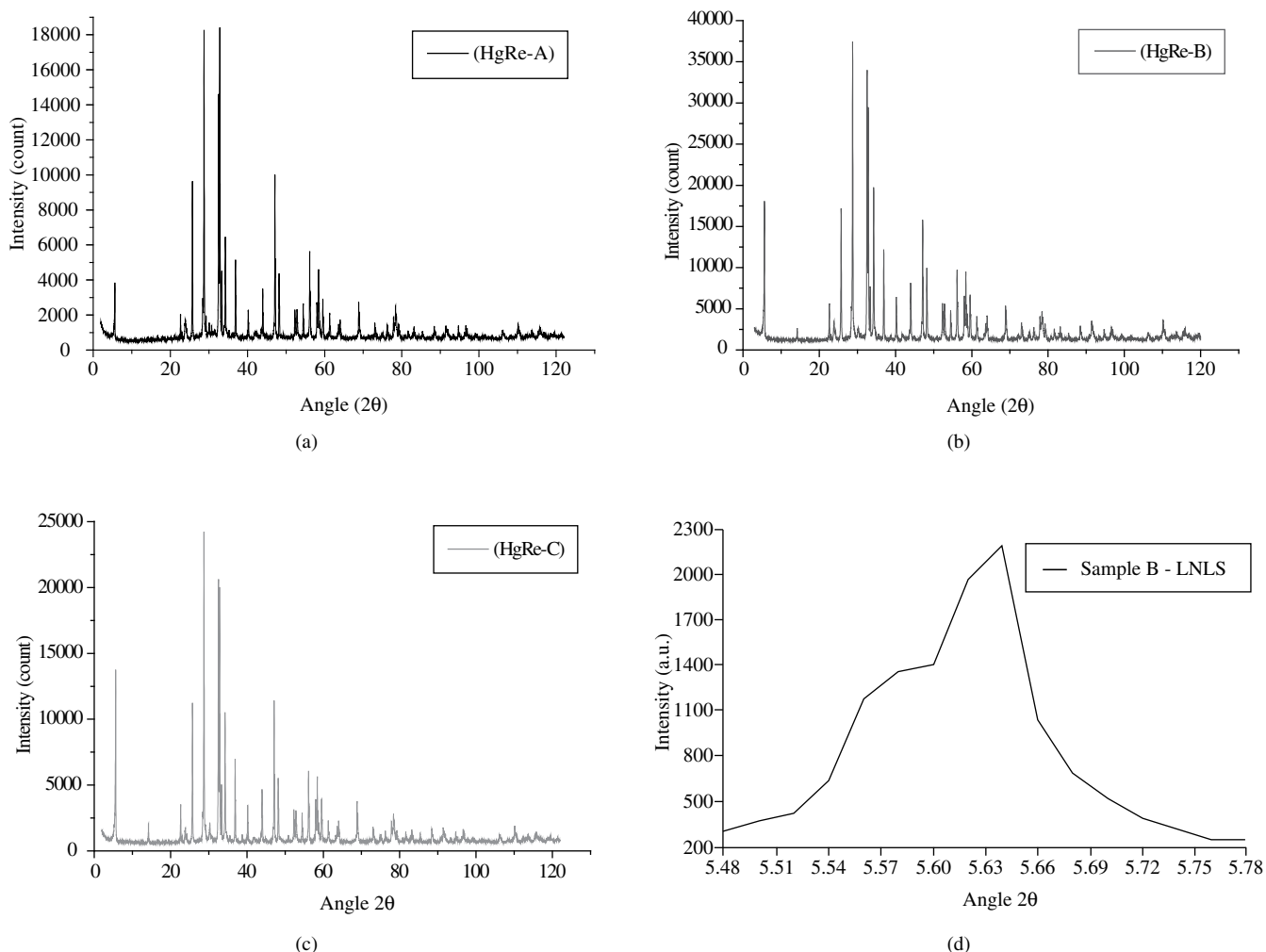

Figure 2. XRD for the samples a) A, b) B and c) C with $\text{Cu}_{k-\alpha}$ radiation and d) detail of the 001 reflection using high resolution Synchrotron diffraction.

Table 3. Identified phases according to Powder Diffraction File - PDF- ICDD

Phase	PDF N ^o	Space Group	Cell Parameters (Å)
$\text{Hg}_{0.80}\text{Re}_{0.20}\text{Ba}_2\text{Ca}_2\text{Cu}_3\text{O}_{8+\delta}$	51-0490	P4/mmm	a = 3.853 c = 15.683
$\text{HgBa}_2\text{Ca}_2\text{Cu}_3\text{O}_{8+\delta}$	87-1338	P4/mmm	a = 3.852 c = 15.851
CaHgO_2	86-0037	$\text{R}\bar{3}\text{m}$	a = 3.586 c = 18.653
BaCO_3	85-0720	Pmcn	a = 5.280 b = 8.830 c = 6.390
$\text{Ca}_{0.82}\text{CuO}_2$	89-6533	Fmmm	a = 2.805 b = 6.320 c = 10.576
Ca_2CuO_3	34-0282	Immm	a = 12.23 b = 3.776 c = 3.257
BaCuO_2	70-0441	Im-3m	a = 18.27
CuO	89-5899	C1c1	a = 4.689 b = 3.420 c = 5.130

By means of high resolution anomalous synchrotron diffraction at the Re L_{III} edge energy, we confirmed the presence of two phases with different contents of Re, as can be seen in Figure 3.

The Rietveld analysis of XRD data was performed by fixing the oxygen co-ordination around Re (values obtained by EXAFS) while refining all other parameters. The details of the analysis method are described in Martinez⁴. The main results are shown in Table 4. The Rietveld plot and the crystal structure of one of the samples are shown in Figure 4.

These results allowed the explanation of intrinsic superconducting properties of these Hg,Re-1223 compounds in terms of their crystal structures¹³.

4. Conclusions

The Rietveld analysis, applied to conventional, synchrotron or neutron diffraction, is considered a very important tool in the study of crystal structures of materials. However, in some cases, powder diffraction analysis alone is not enough to solve intricate structures. The use of combined techniques is essential to the resolution of the crystal structure of a complex compound, as in this case, for instance. In cases like this one, the application of different techniques, in a complementary way, is necessary in order to fully characterize a complex crystal structure^{4,13}. In this work we showed that the ap-

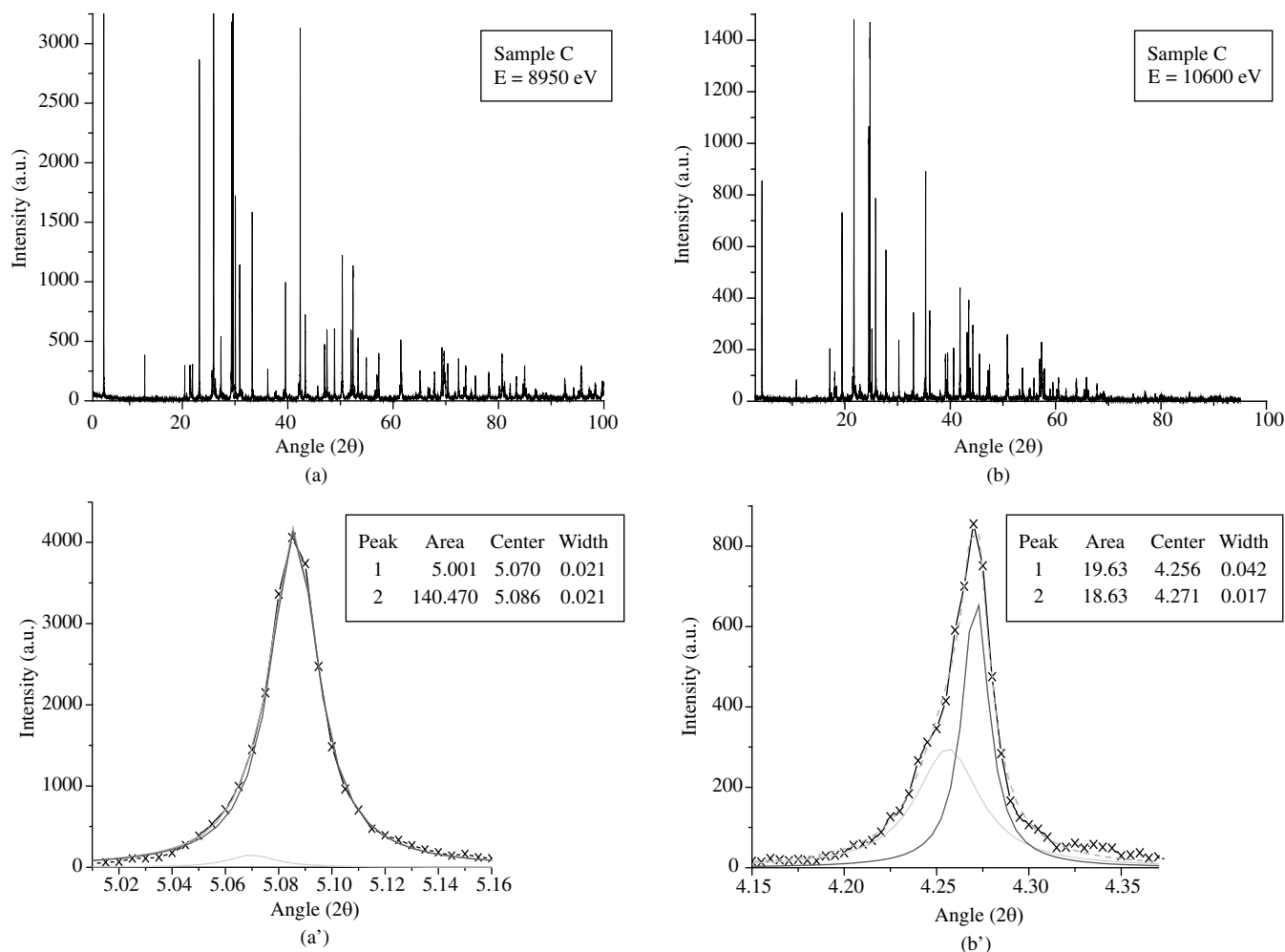

Figure 3. a) Synchrotron anomalous diffraction at energies 8.950 keV and b) 10.600 keV for the same sample. The Figures 3a' and 3b' show the asymmetry and different proportions of the split 001 reflection caused by anomalous scattering¹².

Table 4. Main results of Rietveld fits for the samples A, B and C.

Parameters	Sample A	Sample B	Sample C
% _{mass} phase Hg,Re-1223	61.4	68.7	50.3
% _{mass} phase Hg-1223	16.1	14.7	30.8
% _{mass} superconducting phases	77.5	83.4	81.1
% _{mass} residual phases	22.5	16.6	19.0
Parameter a phase Hg,Re-1223 (Å)	3.8545	3.8541	3.8544
Parameter c phase Hg,Re-1223 (Å)	15.6874	15.6881	15.6891
c/a phase Hg,Re-1223	4.070	4.070	4.070
Unit cell vol. phase Hg,Re-1223 (Å ³)	233.072	233.035	233.082
Angle Cu-O-Cu phase Hg,Re-1223 (°)	176.92	179.93	178.33
O Stoichiometry δ phase Hg,Re-1223	8.707	8.747	8.752
Occupation Hg phase Hg,Re-1223	0.738	0.749	0.749
Occupation Re phase Hg,Re-1223	0.177	0.187	0.188
Occupation site 000 phase Hg,Re-1223	0.915	0.936	0.937
Parameter a phase Hg-1223 (Å)	3.8543	3.8535	3.8543
Parameter c phase Hg-1223 (Å)	15.6988	15.7016	15.6928
c/a phase Hg-1223	4.073	4.075	4.071
Unit cell vol. phase Hg-1223 (Å ³)	233.215	233.163	233.129
Chi ²	1.936	3.268	2.330
Rwp	0.0441	0.0399	0.0461
Rp	0.0346	0.0307	0.0359
DWd	1.040	1.247	0.888
RF ²	0.0615	0.0503	0.0514

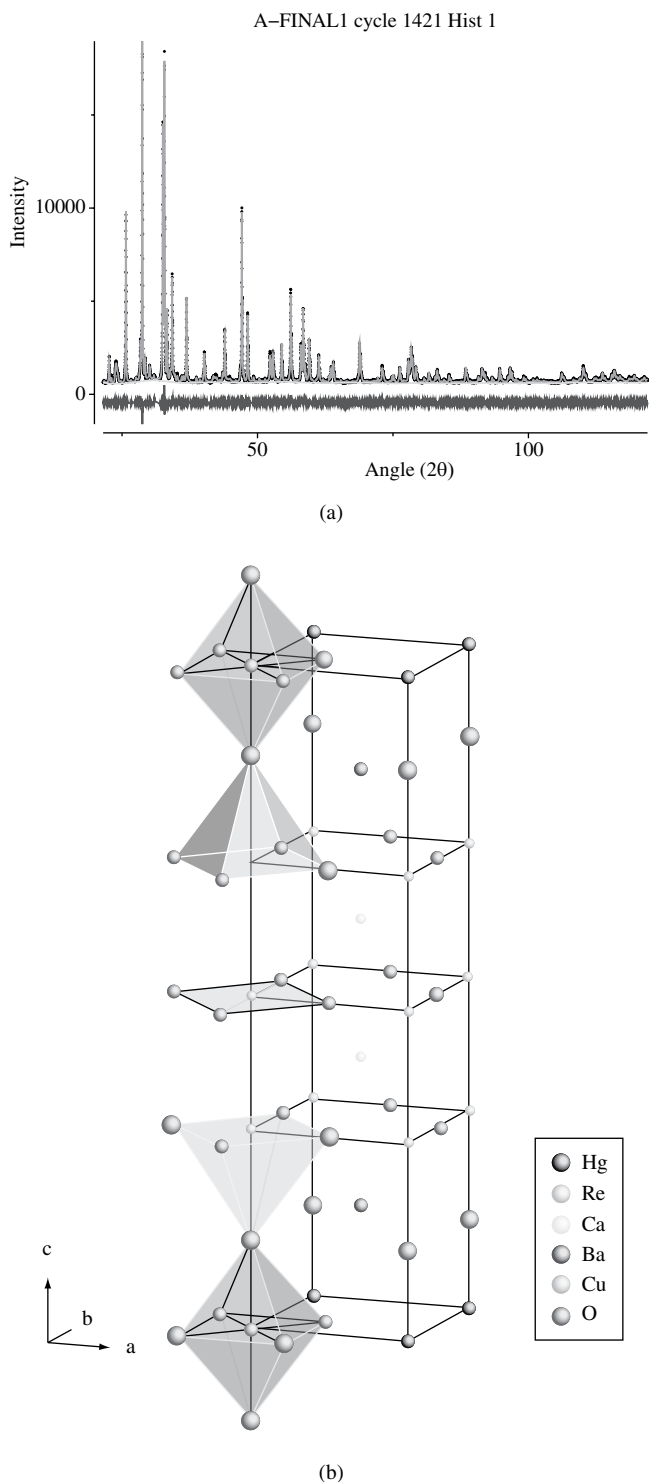

Figure 4. Rietveld plot and corresponding calculated unit cell for sample A.

plication of different techniques of X ray diffraction (normal and anomalous scattering) and absorption (XANES and EXAFS) allowed a good characterization of the crystal structures of Hg,Re-1223 superconducting compounds with different oxygen contents and this procedure can be certainly considered as a viable way to solve other complex crystallographic structures.

Acknowledgements

The authors would like to acknowledge Dr. I. P. Cavalcante for the careful revision of the manuscript and suggestions. C. A. C. Passos acknowledges the Post-Doctoral Program for Young Scientists (CNPq #150824/2007-6).

References

1. Bednorz JG, Müller KA. Possible high T superconductivity in the Ba-La-Cu-O system. *Journal Zeitschrift für Physik B Condensed Matter* 1986; 64(2):189-193.
2. Putilin, S. N., Antipov, E. V., Chmaissem, O., Marezio, M. Superconductivity at 94 K in $\text{HgBa}_2\text{CuO}_{4+\delta}$. *Nature* 1993; 362(6417):226-228.
3. Orlando MTD, Cunha AG, Budko SL, Sin A, Martinez LG, Vanoni W, Belich H, Obradors X, Emmerich FG, Baggio-Saitovitch E. $\text{Hg}_{0.95}\text{Re}_{0.05}\text{Ba}_2\text{Ca}_2\text{Cu}_3\text{O}_{8+\delta}$ superconductor: sample preparation and transport properties under hydrostatic pressure. *Superconductor Science & Technology* 2000; 13:140-147.
4. Martinez LG. *Estudo da Estrutura Cristalina do Composto Supercondutor $\text{Hg}_{1-x}\text{Re}_x\text{Ba}_2\text{Ca}_2\text{Cu}_3\text{O}_{8+\delta}$* . [Ph.D. Thesis]. São Paulo:IPEN/USP; 2005 (in portuguese).
5. Orlando MTD, Sin A, Alsina F, Cunha AG, Mestres N, Calleja A, et al. Effects of re-doping on superconducting properties and formation of Hg-1223 superconductors. *Physica C* 1999; 328(3-4):257-269.
6. Larson AC, Von-Dreele RB. General Structure Analysis System (GSAS). *Los Alamos National Laboratory Report - LAUR*; 2004. p. 86-748.
7. Toby BH. EXPGUI, a graphical user interface for GSAS. *Journal of Applied Crystallography* 200; (34):210-213.
8. Ravel B. Introduction to EXAFS Analysis Using Theoretical Standards. 2001 [Online] [cited 2008/05/21]. Available from: <http://leonardo.phys.washington.edu/~ravel/talks/course/ieauts.pdf>
9. Ravel B. ATOMS: crystallography for the X ray absorption spectroscopist. *Journal of Synchrotron Radiation* 2001 ; (8):314-316.
10. Chmaissem O, Huang Q, Antipov EV, Putilin SN, Marezio M, Loureiro SM, Capponi JJ, Tholence JL, Santoro A. Neutron powder diffraction study at room temperature and at 10K of the crystal structure of the 133K superconductor $\text{HgBa}_2\text{Ca}_2\text{Cu}_3\text{O}_{8+\delta}$. *Physica C* 1993; 217(3-4):265-272.
11. Brown ID, Altermatt D. Bond-valence parameters obtained from a systematic analysis of the inorganic crystal structure database. *Acta Crystallographica* 1985; B41:244-247.
12. Orlando MTD, Martinez LG, Correa HPS. Structural parameters as a function of the Oxygen Content in (Hg,Re) – 1223. [CD-Rom]. Campinas, Brazil:LNLS Activity Report Science Highlights 2003; *Brazilian Synchrotron Light Laboratory*; 2003. p. 311-312.
13. Passos CAC, Orlando MTD, Passamai JL, Mello EVL, Martinez LG. Resistivity study of the pseudogap phase for (Hg,Re)-1223 superconductors. *Physical Review B. Condensed matter and materials physics* 2006; 74(9):94514.1-94514.10.