



An Improved Ion Source for a Compact Cyclotron

F. Dworschak*, W. Kogler*, G. Lucki**, W. Stellmacher*,
 *IFF, KFA Jülich GmbH, 5170 Jülich, FRG, **IPEN, Sao Paulo, Brazil



51/88

Abstract

In recent years the requirements for higher current ion beams revealed some weak points of the cold cathode ion source installed in our compact multiple particle cyclotrons. Two improved versions of this ion source are described and compared. In one version special emphasis was put on an easy exchange of worn out parts. Typical operating characteristics of this ion source will be presented and discussed.

Introduction

A variable-energy compact cyclotron has been in operation at KFA Jülich since 1976. The layout of the facility and the characteristic data of the cyclotron have been published previously [1]. In the past years the demand for both beam time as well as high intensity beams has increased considerably so that special emphasis was placed on optimum beam production. The ion source of the cyclotron is a radially mounted "cold cathode" type hooded arc ion source which can be operated in three modes: 1) cold cathode discharge (PIG); 2) low current (0.86 A) thermionic (LT); 3) high current (3.0 A) thermionic (HT). In both thermionic modes the "cold" cathodes are heated by ion bombardment. The intense use of the cyclotron showed some of the weak points of the ion source. Its relatively short life time due to the strong wear of the cathodes and the head during the production of He ion caused frequent unscheduled shut downs.

Description of Ion Source

The source, which is similar to that shown in Fig. 1, is supported by two tubes – one above and one below the beam plane – to which separate tubes for the colling water and the gas supply are

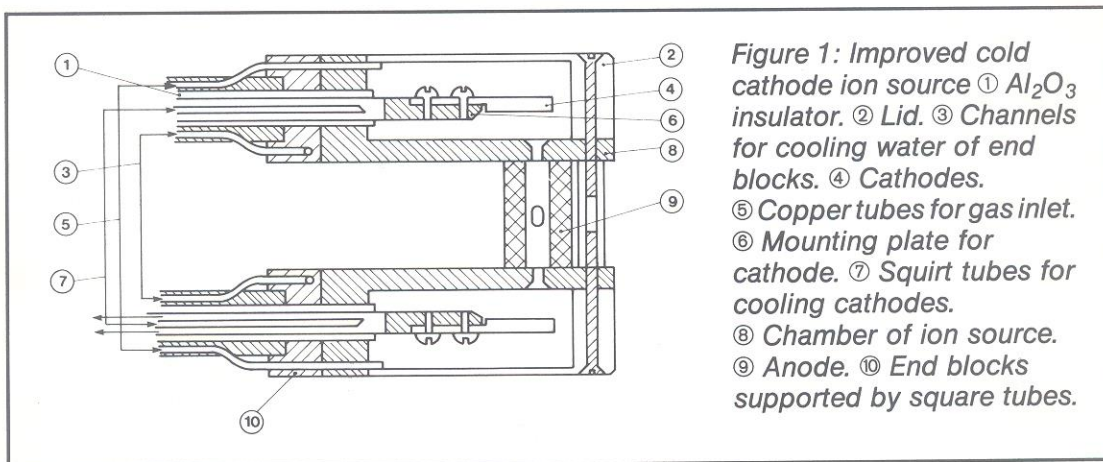

attached. The source itself is symmetric about the center plane and both cathodes are electrically connected externally. The supports onto which the cathodes are bolted are cooled by squirt tubes. The cathodes are made of Ta and have the following dimensions: length: 33 mm; width: 6.3 mm; thickness: 3.0 mm. The anode made of either Alconide or carbon is held by two copper blocks which are water cooled. The Ta cathodes had an average life time of about 25 h. They can easily be replaced by removing the lids and the screws, but the cyclotron

chamber has to be vented and time is lost during the pump down operation. Moreover, after several weeks of operation the whole head wears out so that at least the ion source with the tubes must be replaced. A typical worn out ion source is shown in Fig. 2.

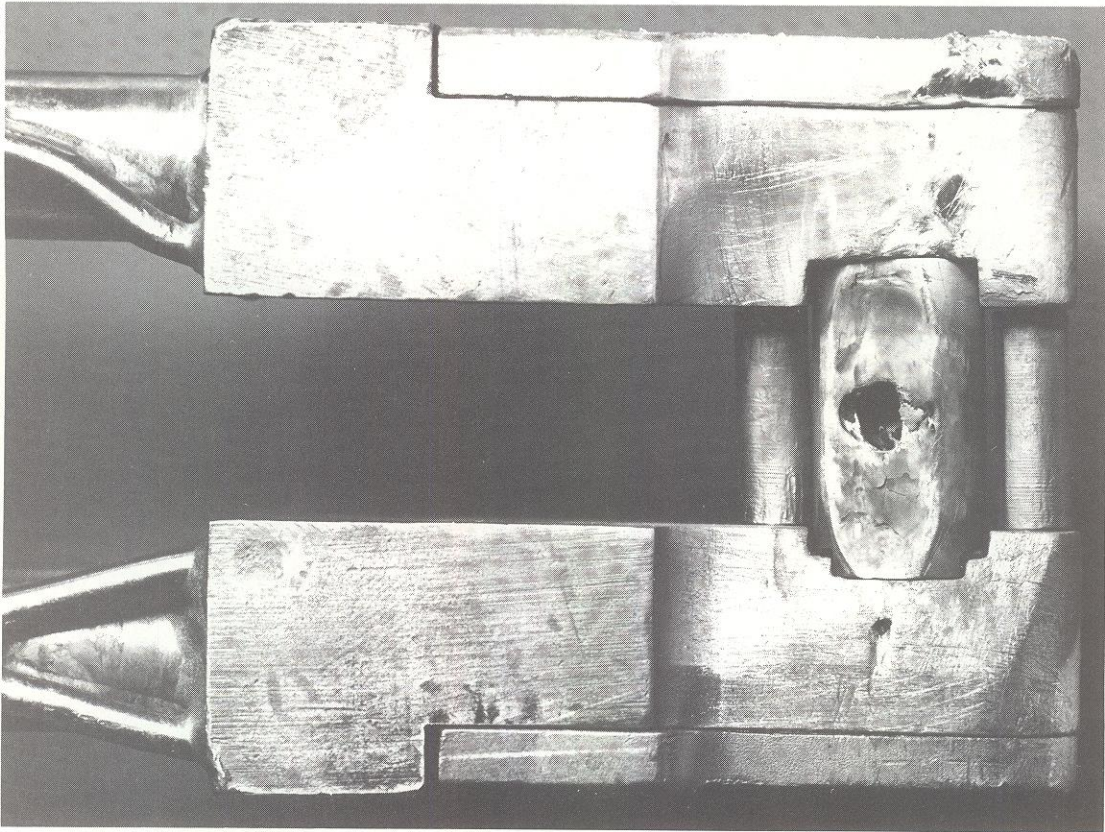

Figure 2: Worn out ion source.

Improvement Studies

Since a frequent replacement of the inner parts of the ion source became prohibitive we started a test program to increase the life time of this ion source. Part of the fast wear of the chamber was thought to be caused by ineffective cooling. Therefore, an ion source was constructed with a very efficient cooling of the copper blocks (part 8 in Fig. 1). This was achieved by milling appropriate grooves into the walls of the chambers and filling them with wax. The surfaces were then electroplated with a layer of copper of about 0.5 mm thickness and then the wax was dissolved. With this technique the pipes for the cooling water were incorporated directly into the chambers. The gas was fed into the anode chamber. This source was tested both in the compact cyclotrons of Sao Paulo and KFA Jülich and found to produce less beam current than the original source. Moreover, the production of α -particles and ^3He ions turned out to be not very satisfactory, so that the operation of this source was stopped although the lifetime of the head was considerably longer than that of the original one.

As a result we constructed another prototype of an ion source putting special emphasis on an easy exchange of worn out parts, which should be simple to build. This source, which is shown in Fig. 1, is similar to the original one but with two major differences: 1) The tip of the head can be replaced just as easily as the cathodes. Consequently, the copper blocks holding the anode had to be pressed onto the endblocks of the support tubes and could not be cooled directly any more. 2) The gas is now fed through separate tubes into the lower and the upper cathode chamber.

Operating Characteristics

The dependence of the ion beam current on the accelerating potential, i. e. the Dee-Voltage, and the gas consumption of this ion source was measured. The flow rate of the cooling water was $0.2 \text{ m}^3/\text{h}$, its temperature 16°C . The vacuum in the cyclotron chamber varied between $1.5 \times 10^{-5} \text{ mb}$ and $5 \times 10^{-5} \text{ mb}$ depending on the gas consumption of the ion source. The ion beam current was measured with an internal beam probe set at a radius of about 0.15 m . Some of the operating characteristics are shown in the following figures.

Figs. 3a and 3b give the dependence of the ion beam current on the Dee-Voltage. The value V_{Dee}^0 is 0.1 kV less the lowest voltage for which an ion current could be measured. As may be expected the current increases with increasing accelerating potential, i. e. the Dee-Voltage, for all

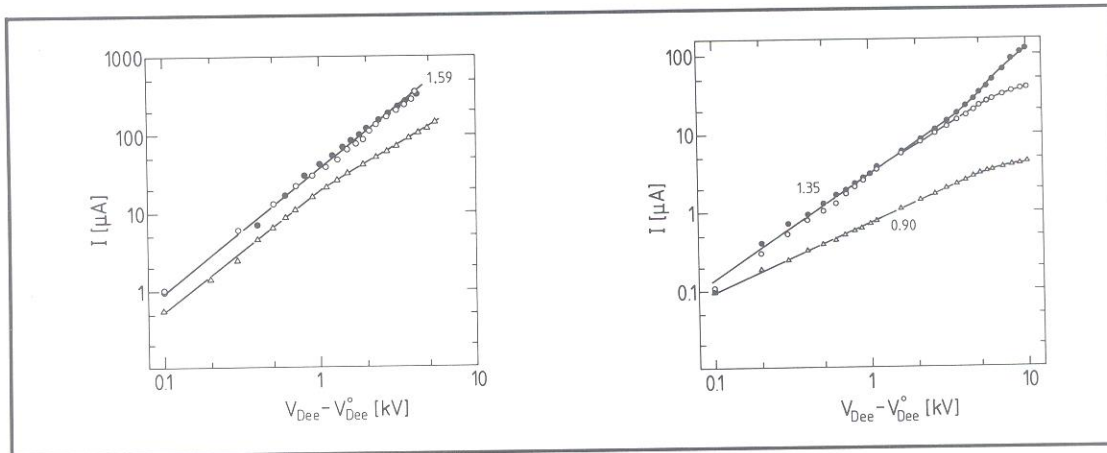

Figure 3a: Dependence of proton beam current at 0.15 m radius on Dee-Voltage for different modes of operation in a log-log plot Δ : PIG mode; \circ : LT mode; \bullet : HT mode.

Figure 3b: Dependence of α -beam current at 0.15 m radius on Dee-Voltage for different modes of operation in a log-log plot Δ : PIG mode; \circ : LT mode; \bullet : HT mode.

particles and for all three modes of operation. In the log-log plots of the data the slope is rather close to that given by the space charge equation for current intensity

$$j = k \cdot V^{3/2}$$

with the exception for the PIG mode for α particles.

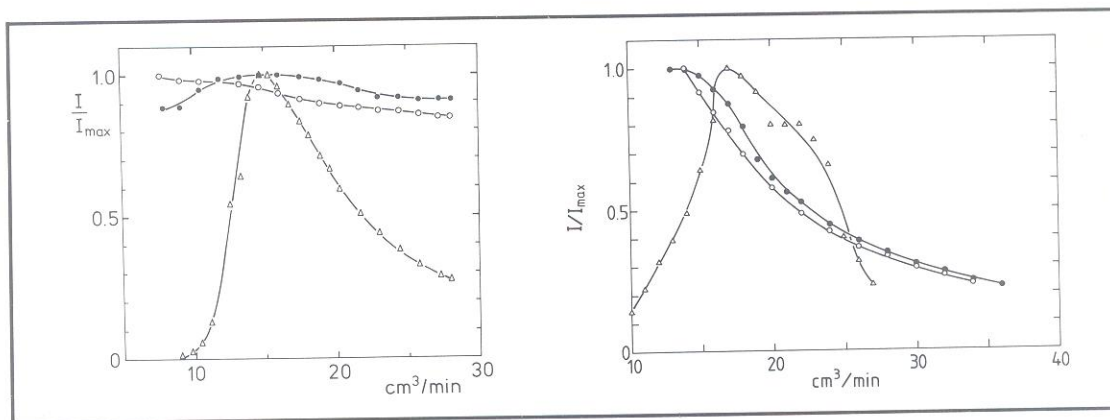

Figure 4a: Dependence of normalized beam current at 0.15 m radius for 20 MeV protons on hydrogen flow rate. Δ : PIG mode, $I_{\text{max}} = 21.8 \mu\text{A}$; \circ : LT mode, $I_{\text{max}} = 92 \mu\text{A}$; \bullet : HT mode, $I_{\text{max}} = 122 \mu\text{A}$.

Figure 4b: Dependence of normalized beam current at 0.15 m radius for 28 MeV α on He flow rate. Δ : PIG, $I_{\text{max}} = 3.5 \mu\text{A}$; \circ : LT mode, $I_{\text{max}} = 29.5 \mu\text{A}$; \bullet : HT mode, $I_{\text{max}} = 60.5 \mu\text{A}$.

The dependence of the ion beam current on the gas consumption is shown in Figs. 4 a and 4 b for the different ion species and the three different modes of operation. The Dee-Voltage was not changed between the different modes of operation, but was varied for different ion species. In the thermionic modes maximum beam currents are obtained at low flow rates, i. e. if the pressure in the discharge is reduced leading to an increase of the arc voltage. The increased arc voltage probably produces a greater secondary emission current from the cathodes, increases the power dissipated in the arc, giving greater cathode heating and enhances the possibility of each electron making more ionizations before losing its energy. At high flow rates, i. e. in the high pressure region, the self-heated cathodes may tend to cool with the increase of pressure.

In the case of the PIG mode the ion output shows a bell shaped dependence upon the flow rate with the maximum ion output occurring between 15 and 20 cm³/min. depending on the ion species.

The arc power varied according to the impedance of the arc, which depends upon the gas consumption. As can be seen in Figs. 5 a und 5 b the ion beam current increases with increasing arc power. For protons the beam current saturates at an arc power of about 400 W so that operating the source in the LT mode is sufficient for most applications. This is not the case for α -particles for which the beam current can be enhanced considerably by an increase of the arc power, i. e. by operating the source in the HT mode.

This ion source has been in operation since January 1987 and has proven to be very reliable with a long life time. It is normally operated at low gas feed rates resulting in a better vacuum of the cyclotron chamber. The life time of the Ta-cathodes has increased considerably (up to a factor 10); under optimum condition cathodes have lasted 420 h.

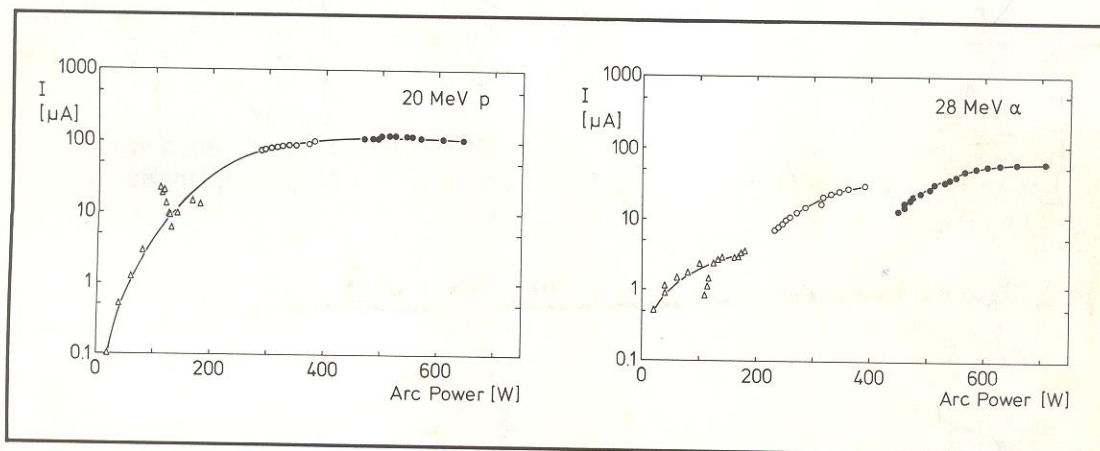

Figure 5a: Dependence of the ion beam current on the arc power; Δ : PIG mode; \circ : low thermionic mode; \bullet : high thermionic mode.

Figure 5b: Dependence of the ion beam current on the arc power; Δ : PIG mode; \circ : low thermionic mode; \bullet : high thermionic mode.

Acknowledgement

The authors are indebted to Mr. D. Nentwich and Mr. H. D. Talarek from INT of KFA Jülich on the German and to Mr. Rex Nazare Alves CNEN on the Brazilian side who continuously supported this research and development project. Without the generous travel grants given by these agencies this international cooperation would not have been possible. Many thanks are also due to the technical staff of the cyclotrons in Sao Paulo and IFF, KFA Jülich.

References

- [1] Hemmerich, J., Hölzle, R., Kogler, W.
"The Jülich compact cyclotron – a multipurpose irradiation facility", *Kerntechnik* **19**, pp. 67 – 70, 1977.