

QUALIFICATION PROCESS OF DISPERSION FUELS IN THE IEAR1 RESEARCH REACTOR

D. B. DOMINGOS, A. T. SILVA, J. E. R. SILVA

Instituto de Pesquisas Energéticas e Nucleares (IPEN/CNEN-SP)

Av. Professor Lineu Prestes, 2242, Cidade Universitária, 05508-000 São Paulo, SP - Brazil

ABSTRACT

Neutronic, thermal-hydraulics and accident analysis calculations were developed to estimate the safety of a miniplate irradiation device (MID) to be placed in the IEA-R1 reactor core. The irradiation device will be used to receive miniplates of U_3O_8 -Al and U_3Si_2 -Al dispersion fuels, LEU type (19,9% of ^{235}U) with uranium densities of, respectively, 3.0 gU/cm^3 and 4.8 gU/cm^3 . The fuel miniplates will be irradiated to nominal ^{235}U burnup levels of 50% and 80%, in order to qualify the above high-density dispersion fuels to be used in the Brazilian Multipurpose Reactor (RMB), now in the conception phase. For the neutronic calculation, the computer codes CITATION and TWODB were utilized. The computer code FLOW was used to calculate the coolant flow rate in the irradiation device, allowing the determination of the fuel miniplate temperatures with the computer model MTRCR-IEA-R1. A postulated Loss of Coolant Accident (LOCA) was analyzed with the computer code LOSS and TEMPLOCA, allowing the calculation of the fuel miniplate temperatures after the reactor pool draining. This paper also presents a system designed for fuel swelling evaluation. The determination of the fuel swelling will be performed by means of the fuel miniplate thickness measurements along the irradiation time.

1. Introduction

The IEA-R1 reactor of IPEN-CNEN/SP in Brazil is a pool type research reactor cooled and moderated by demineralized water and having Beryllium and Graphite as reflectors. In 1997 the reactor received the operating licensing for 5 MW. Since 1998, IPEN has been producing and qualifying its own U_3O_8 -Al and U_3Si_2 -Al dispersion fuels. The U_3O_8 -Al dispersion fuel is qualified up to a uranium density of 2.3 gU/cm^3 and the U_3Si_2 -Al dispersion fuel up to 3.0 gU/cm^3 [1]. The IEA-R1 reactor core is constituted of the fuels above, with low enrichment in ^{235}U (19.9% of U-235). IPEN has no hot cells to provide destructive analysis of the irradiated fuel. As a consequence, non destructive methods have been used to evaluate irradiation performance of the fuel elements [2]. For fuel qualification, complete fuel elements were irradiated in the IEA-R1 reactor core and the fuel element evaluation consisted of two items: i) monitoring the fuel performance during the IEA-R1 operation for the following parameters: reactor power, time of operation, neutron flux at the position of each fuel assembly, burnup, inlet and outlet water temperature in core, water pH, water conductivity, chloride content in water, and radiochemistry analysis of reactor water; ii) periodic underwater visual inspection of fuel assemblies and eventual sipping test for fuel element suspect of leakage. Irradiated fuel elements have been visually inspected periodically by an underwater radiation-resistant camera inside the IEA-R1 reactor pool, to verify its integrity and its general plate surface conditions.

Nowadays, IPEN-CNEN/SP is interested in qualifying the above dispersion fuels at higher densities. Ten fuel miniplates, five of U_3O_8 -Al fuels and five of U_3Si_2 -Al fuels, with densities of, respectively, 3.0 gU/cm^3 and 4.8 gU/cm^3 , which are the maximal uranium densities qualified in the world for these dispersion fuels, were fabricated at IPEN-CNEN/SP. The miniplates will be put in an irradiation device, with similar external dimensions of IEA-R1 fuel

elements, which will be placed in a peripheral position of the IEA-R1 reactor core. In order to certify miniplate safety irradiation in the IEA-R1 reactor core, neutronic, thermal-hydraulics and accident analysis calculations were developed.

2. Neutronic, Thermal Hydraulics and Accident Analysis Calculation for the Irradiation Device

A special Miniplate Irradiation Device (MID) was designed for irradiation of the fuel miniplates in the IEA-R1 reactor. Figure 1 shows the MID. The MID has the external dimensions of the IEA-R1 fuel element. The miniplates will be allocated in a box with indented bars placed inside the external part of the MID. Figure 2 shows the transversal section of the MID.



Fig 1: Miniplate Irradiation Device – MID.

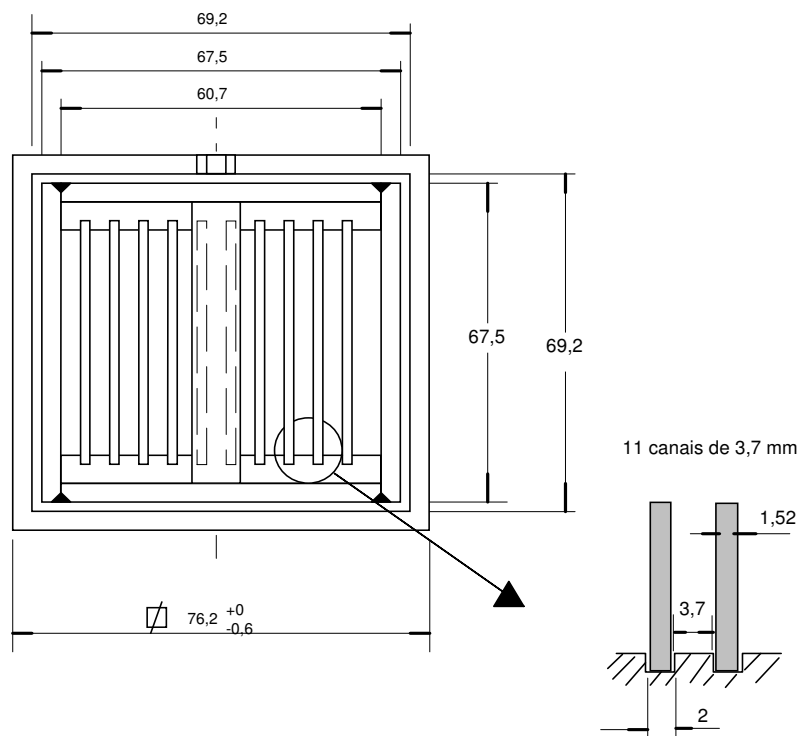

Fig 2: Transversal section of the MID (dimensions in mm).

As seen from Figure 2, up to ten miniplates can be placed in the box with indented bars inside of the MID. The qualification of the U_3O_8 -Al and U_3Si_2 -Al dispersion fuels with higher ^{235}U density will be made in use, which is based on the irradiation of the dispersion fuel miniplates in the IEA-R1 reactor followed by the use of non-destructive analysis techniques, mainly fuel miniplate visual inspections performed regularly with a radiation-resistant underwater camera [2].

A new special system [3] was designed for the fuel miniplate swelling determination. The fuel swelling determination will be performed by means of the fuel miniplate thickness measurement during the irradiation period in the IEA-R1 reactor. During the measuring period, the fuel miniplates will be transferred from the reactor core to the measurement system. Figure 3 shows the fuel miniplate thickness measurement system. It consists of a mobile metallic column held by an X-Y coordinate table system for miniplate thickness measurement. The table is supported by another metallic structure fixed at the border of the reactor pool. The thickness measurement is performed by electronic probes (LVDT). The results are obtained through the instrumentation connected to the probes. The system is operated from the reactor pool border.

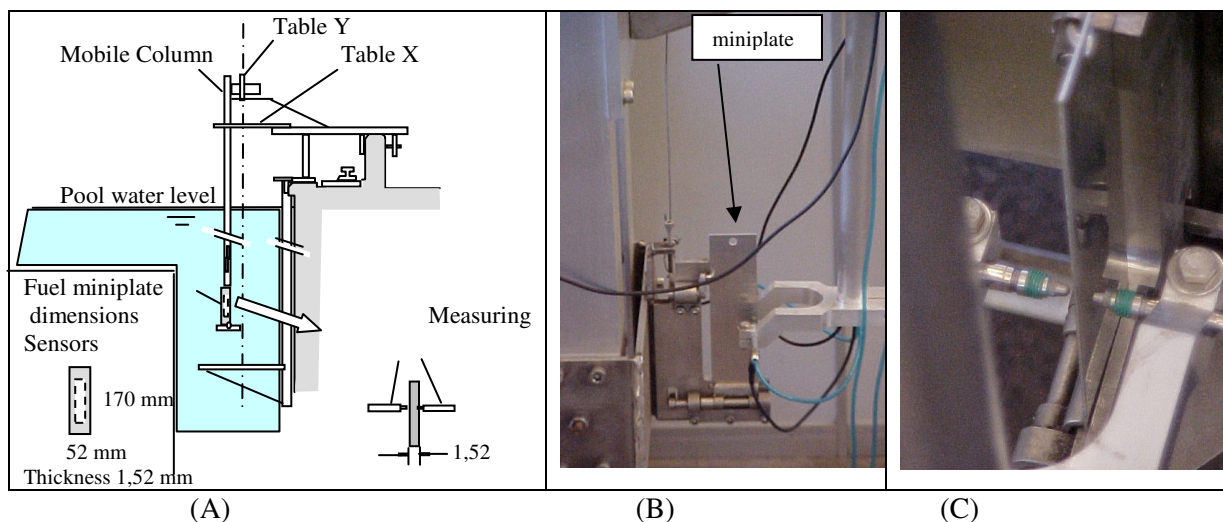

Fig 3: Fuel miniplate thickness measurement apparatus at IEA-R1: (A) schematic view at the reactor pool border; (B) lateral view; (C) profile view (thickness).

For commissioning the measurement system in the reactor pool area, two sets of measurements were made. The first set of measurements consisted of thickness measurements of an aluminum dummy miniplate, outside the reactor pool. These measurements evaluated the system performance in dry condition. The second set of measurements was performed for another dummy miniplate in the reactor pool. Dimensional results were in good accordance with those of the standards blocks supplied by TESA [4]. The results showed that the equipment was efficient and accurate, with measurement precision of 1 μm .

2.1 Neutronic calculation for the irradiation device

In the neutronic calculation, the computer code CITATION [5] was used for the three-dimensional core calculation and for burnup calculation. The cross sections were generated by the computer code TWODB [6]. The calculated radial and axial density curves were used as input data for the thermal-hydraulics reactor core and MID analysis. The core configuration number 236 of the IEA-R1 reactor [7] was used, with 24 elements, being 20 standard elements of U_3O_8 -Al and U_3Si_2 -Al dispersion fuels, four control elements, and one beryllium irradiation element in the central position of the core. In the calculation was considered that every fuel miniplate was made of U_3Si_2 -Al with a uranium density of 4.8

gU/cm^3 . In this situation will be generated the maximal power density in the miniplates, due to the maximal uranium density used. Three positions in reactor core matrix plate were given by the reactor operation to place the MID: 1) position 26; 2) position 37; and 3) position 36. In order to define the best position for the miniplate irradiation, calculations of the power densities were developed for three positions. The maximal power density was obtained for the position 36. In this position the miniplates will achieve the highest burnup in the shortest period of time.

2.2 Thermal-Hydraulics Analysis

A new thermal-hydraulics model MTCR-IEA-R1 [8] has been developed in 2000 at IPEN-CNEN/SP using a commercial program Engineering Equation Solver (EES). The use of this computer model enables the steady-state thermal and hydraulics core analyses of research reactors with MTR fuel elements. The following parameters are calculated along the fuel element channels: fuel meat central temperature (T_c), cladding temperature (T_r), coolant temperature (T_f), Onset of Nucleate Boiling (ONB) temperature (T_{onb}), critical heat flux (Departure of Nucleate Boiling-DNB), flow instability and thermal-hydraulics safety margins MDNBR and FIR. The thermal-hydraulics safety margins MDNBR and FIR are calculated as the ratio between, respectively, the critical heat flux and the heat flux for flow instability and the local heat flux in the fuel plate. Furthermore, the MTCR-IEA-R1 model also utilizes in its calculation the involved uncertainties in the thermal-hydraulics calculation such as: fuel fabrication uncertainties, errors in the power density distribution calculation, in the coolant flow distribution in the core, reactor power control deviation, in the coolant flow measures, and in the safety margins for the heat transfer coefficients. The calculated thermal-hydraulics core parameters are compared with the design limits established for MTR fuels: a) cladding temperature $< 95^\circ\text{C}$; 2) safety margin for ONB > 1.3 , or the ONB temperature higher than coolant temperature; 3) safety margin for flow instability > 2.0 ; and 4) safety margin for critical heat flux > 2.0 .

The placement of the MID in the matrix plate of IEA-R1 reactor will deviate part of the reactor coolant flow to cool the fuel miniplates. The flow rate in the core of the reactor IEA-R1 is 3400 gpm which provides a flow rate of approximately $20 \text{ m}^3/\text{h}$ per fuel element, sufficient to cool a standard fuel element. Results of the parametric tests developed with the program MTCR-IEA-R1 showed the need of a minimum flow rate of $10 \text{ m}^3/\text{h}$ through the MID. The simulations have considered the MID with ten identical miniplates, with the same composition ($\text{U}_3\text{Si}_2\text{-Al}$), with the same uranium density (4.8 gU/cm^3), in order to analyze the most critical device configuration. The value of $12,3 \text{ m}^3/\text{h}$ was defined for the coolant flow rate through the MID. It is sufficient to cool the miniplates and represent only a small deviation of the total coolant flow rate in the reactor core. A special flow restrictor was fabricated in order to maintain this coolant flow rate in the MID (see Figure 1).

No design limit was achieved for the analyzed irradiation device. The calculated cladding temperatures are below the value of 95°C , and the coolant temperatures are below the ONB temperature, indicating one-phase flow through the MID. The margins for critical heat flux (MDNBR) and flow instability (FIR) are well above the value of 2.0, admitted as design limit.

2.3 Accident Analysis

The Loss of Coolant Accidents (LOCA) in pool type research reactors are normally considered as limiting in the licensing process. For the IEA-R1 research reactor, a special Emergency Core Cooling System (ECCS) was constructed in order to avoid the core melting during a postulated primary coolant boundary rupture. With two redundant systems with passive action, the ECCS will be able to cool the reactor core after a reactor pool draining. However, the action of this system is limited to the boundaries of the reactor core and the ECCS is not able to cool the MID which is placed in a reactor core peripheral position. Two

computer codes LOSS [9] and TEMPLOCA [9] were used to calculate the temperatures achieved in the fuel miniplates during the core draining. The computer code LOSS determines the time to drain the reactor pool down to the level of the bottom of the core, and the computer code TEMPLOCA can calculate the maximal temperature to be achieved in the fuel miniplate during this transient. The calculations showed that about 7.5 min are necessary to drain the reactor pool during a postulated primary coolant boundary rupture accident. After the pool draining, the maximal fuel miniplate temperature achieved was 180 °C, below the blistering temperature, which is the fuel temperature design limit [9]. At the blistering temperature the fuel miniplate will swell due to the fission gases released in the fuel and can close the fuel miniplate cooling channels with the fuel temperature increasing up to miniplate melting. The value of blistering temperature for dispersion fuels can vary between 350 °C e 600 °C, depending on dispersion fuel type, fuel enrichment and burnup achieved.

3. Conclusions

The neutronic calculations showed that the inclusion of the MID in the IEA-R1 reactor core will not affect its operation, since the change in reactor reactivity will be irrelevant. The best reactor core position for miniplate irradiation is the core position 36, which will have the highest power density, allowing higher burnup in a shorter period of time. Through thermal-hydraulics calculations was determined that a flow rate of 12,3 m³/h will be sufficient for cooling the fuel miniplates and will represent only a small deviation of the total coolant flow rate in the reactor core (600 m³/h). The accident analysis concluded that there will not be done any damage to the miniplates in case of a postulated primary coolant boundary rupture.

4. References

1. A.T. Silva, L.A.A. Terremoto, J.E.R. Silva, C.T. Almeida, M.A. Damy, P.E. Umbehaun, M. Yamaguchi, "Qualification program of research reactor fuels manufactured at IPEN-CNEN/SP", Progress in Nuclear Energy 50 (2008) 795-799.
2. J.E.R. Silva, A.T. Silva, L.A.A. Terremoto, "Inspection experience with IEA-R1 spent fuel and non-destructive methods for qualification of high density LEU fuel (U₃Si₂-Al) at IPEN-CNEN/SP", In: RRFM 2009, Vienna. Transactions RRFM 2009. Brussels, Belgium: European Nuclear Society, 2009. v. 1.
3. J.E.R. Silva, D.B. Domingos, A.T. Silva "Fuel miniplate thickness measurement system for dispersion fuel swelling evaluation", 2009 International Atlantic Conference - INAC 2009, Rio de Janeiro-RJ, Brazil, September 27 to October 2, 2009.
4. Manual of the module for Electronic Length Measurements; TESA, model TESATRONIC TT60.
5. T.B. Fowler, D.R. Vondy, G.W. Cunningham, – "Nuclear Reactor Core Analysis Code: CITATION", Oak Ridge National Laboratory, ORNL-TM-2496, Ver. 2, July, (1971).
6. W.W. Little, Jr. and R.W. Hardie, 2DB, "A Two-dimensional Diffusion Burnup Code for Fast Reactor Analysis" BNW640, January 1968, Addendum and Errata, April 12, 1968.
7. D.B. Domingos, A.T. Silva, P.E. Umbehaun, J.E.R. Silva, T.N. Conti, M. Yamaguchi - "Neutronic, thermal-hydraulic and accident analysis calculations for an irradiation device to be used in the qualification process of dispersion fuels in the IEA-R1 research reactor", 2009 International Atlantic Conference - INAC 2009, Rio de Janeiro-RJ, Brazil, September 27 to October 2, 2009.
8. P. E. Umbehaun, – "Metodologia Para Análise Termo-Hidráulica de Reatores de Pesquisa Tipo Piscina com Combustível Tipo Placa" – Dissertação de Mestrado – São Paulo, (2000).
9. E. Maprelian, – "Análise de Acidente de Perda de Refrigerante no Reator IEA-R1 a 5MW" – Dissertação de Mestrado – São Paulo, (1998).