

A new electrolytic dissolution of aluminum alloys and determination of some constituents by inductively coupled plasma optical emission spectrometry

Tânia Grigoletto^{a,*}, Elisabeth de Oliveira^b, Ivano G.R. Gutz^b

^a Instituto de Pesquisas Energéticas e Nucleares (IPEN-CNEN/SP), Caixa Postal 11049, 05422-970, São Paulo, Brazil

^b Instituto de Química, Universidade de São Paulo, 05508-900, São Paulo, Brazil

Received 9 November 2004; received in revised form 1 April 2005; accepted 4 April 2005

Available online 11 May 2005

Abstract

The new electrolytic dissolution in batch of aluminum alloys samples as grains or turns and the determination of Fe, Cu, Mn, Mg, Cr, Ni, Zn, Pb and Ti by ICP OES was investigated. In on-line electrodisolution procedures described in the literature, samples were restricted to be in the form of solid blocks or plates with one polished flat face. Here, the sample was loaded in the barrel of a modified disposable syringe (the anodic semi-cell) and pressed with a modified plunger fitted with a platinum disk to establish electrical contact with the analyte. This arrangement was introduced in a beaker containing the electrolyte ($1 \text{ mol L}^{-1} \text{ HNO}_3$) and a platinum wire as the cathode. The resulting solution from electrodisolution (0.6 A) was used for the ICP OES determinations. The influence of the aluminum concentration increase on the determination of the elements was evaluated. Electrodisolution of certified reference materials and commercial samples revealed relative errors lower than 10% for the elements Fe, Cu, Mg, Ni, Cr, Zn and Ti (when their content is above 0.1%). Higher inaccuracies (>10%) were observed for Mn and for Fe in B.C.S. 268/1 reference material certified. The proposed method presented a relative standard deviations (R.S.D.) lower or circa 10% to all of the elements (except Pb). In comparison with traditional acid dissolution, the proposed electrodisolution method is relatively fast (about 30 min), it is clean (there is no projection of solution) and simple (heating and fumes exhaust system were not necessary).

© 2005 Elsevier B.V. All rights reserved.

Keywords: Electrolytic dissolution; Aluminum alloys; ICP OES; Spectroscopy

1. Introduction

Decomposition or dissolution of metal samples is the step that takes most time in spectroscopic methods like ICP OES, FAAS or ICP MS. Electrolytic dissolution has been proposed as an alternative to accelerate sample dissolution procedure of some metals or alloys, in batch mode [1,2] and on-line mode [3–15]. On-line electrolytic dissolution system was first proposed by Bergamin et al. [3] for the determination of soluble aluminium in steels and that cell was used in procedure of the subsequent papers [4–6]. Electrodisolution on-line of Al

alloys was proposed by Yuan et al. [5] for the determination of Cu by FAAS and for the determination of Zn, Si, Fe, Mn, Cr, Mg and Cu by ICP OES [6]. A modified electrodisolution cell was proposed by Bergamin and co-workers [7] and, since then, it has been mentioned in all others papers with some variations in manifold systems [8–15].

The on-line approach is very convenient because the outlet of the electrochemical flow cell can be introduced directly in the torch of the ICP or flame atomic absorption spectrometry and the whole procedure takes a few seconds or minute [3–15]. However, the metal sample must present at least one flat and smooth face with an available free circular area of, typically, 1 cm in diameter, to be clipped without leakage to the cell. The nonuniformity in the material of samples caused by their physicochemical properties (limited

* Corresponding author. Tel.: +55 21 11 3816 9338; fax: +55 21 11 3816 9325.

E-mail address: tgrigole@ipen.br (T. Grigoletto).

solubility of components, impurities in the matrix solid solution, formation of various structural components, etc.) was not taken into account in flowcells proposed [16]. Aluminum alloys are systems that can have various elements on the composition and diverse phases can be present. The alloying elements can be divided into three groups: (1) Cu, Mg and Zn, which form solid solutions with Al, constituting one phase; (2) Si and Sn, which form eutectics, constituting two phases; (3) Fe, Mn, Ni, Cr and Ti, which are not very soluble in Al, forming different phases or intermediary compounds (e.g. Al_3Fe) [17]. Also, with some frequency, not only the samples but also standards are available in the form of powder, sawing, grains, particles, turns, wires, sponge or chips. The effect of the nonuniformity could be decreased by a longer time and a larger mass submitted to the electrolysis, but not the electrodisolution preference of elements in different phases.

In this work, a new electrochemical cell is evaluated to deal with these forms, avoiding the need (and contamination risks) of melting such materials and machining them to permit their electrodisolution using the flow cells described in the literature. Electrodisolution of small metal particles was proposed in combination with ICP OES for the determination of elements Fe, Cu, Mn, Mg, Cr, Ni, Zn, Pb and Ti in aluminum alloys. The effect of the aluminum concentration on the determination of the studied elements was evaluated [18].

2. Experimental

2.1. Reagents, standards and samples

Nitric acid of analytical-reagent grade was used for preparing 1.0 mol L^{-1} nitric acid electrolyte. All solutions were prepared with distilled, deionized water (Milli-Q). Titrisol (Merck) metal standard solutions and nitric and/or hydrochloric acids of analytical-reagent grade were used in the preparation of the calibration solutions for ICP OES whenever necessary.

The analyzed samples were five certified reference materials of Al alloys from British Chemical Standards (B.C.S. no. 182/2, 216/2, 263/2, 268/1 and 380) and Al commercial alloys: (a) alloy T, from Metal Leve Ltd. (Brazil); (b) alloy nos. 2024 and 7075, from Instituto de Pesquisas Tecnológicas do Estado de São Paulo (Brazil); (c) alloy no. 6061/T6, from Alcoa Alumínio S.A. (Brazil). The following samples present high Si content: B.C.S. 182/2 (with 11.02%), B.C.S. 268/1 (with 5.49%), B.C.S. 380 (with 2.00%) and T (with 11.0–13.0%).

Alloys, certified or not, were dissolved anodically by the proposed method. Five solutions were prepared with increasing concentrations of aluminum (1.2, 2.2, 4.2, 6.2 and 8.2 mg mL^{-1}) and constant concentrations of the minor constituents ($200 \text{ } \mu\text{g mL}^{-1}$ of Mg; $80 \text{ } \mu\text{g mL}^{-1}$ of Fe, Cu, Cr and Ni; $100 \text{ } \mu\text{g mL}^{-1}$ of Mn, Zn and Ti; $20 \text{ } \mu\text{g mL}^{-1}$ of Pb).

Thus, the interference of growing aluminum concentration on the determination of the other elements was evaluated.

2.2. Total-acid dissolution

All aluminum alloys were also dissolved by conventional chemical dissolution in order to compare the results with electrodisolution samples. One of the most general methods applied as dissolution procedure includes a combination of HCl and H_2O_2 , but this approach may not completely dissolve all elements. The method used here was a mixed acid of HCl and HNO_3 (aqua regia) and the addition of H_2O_2 to ensure total oxidation of all components (except Si) of the alloy [19]. An open vessel acid dissolution was used: aqua regia (10 mL) was slowly added to 500 mg of Al alloy grains and, after the reaction subsided, the mixture was boiled for 20 min. Then, 5 mL of H_2O_2 was added and boiling was repeated. The solution was filtered (Si) and the residue was washed with small portions of hot water. All portions were collected in a beaker, evaporated up to reduction to ca. 20 mL, transferred to a 50 mL volumetric flask and diluted with water. These solutions, or the ones resulting from a 10 times dilution, were used for determination of the elements of interest by ICP OES. Attacks of the Si residue with HF, posterior dissolution with 1 M HNO_3 and addition of the resulting solution to that evaporated for reduction of the volume, have not showed differences to be taken into account in the analytic results.

2.3. Anodic semi-cell

2.3.1. Apparatus

A simple device was constructed to establish electrical contact with the aluminum sample (grains, powder, turns, chips, etc.). The plunger of a 2.5 mL polypropylene disposable syringe was replaced by a modified plunger consisting of a Perspex rod with two longitudinal perforations: one in the center, for the insertion of a platinum wire to establish electrical contact with the sample; the second one, out of the center and emerging radially near the lower end of the rod (Fig. 1) serving as a conduit for the electrolyte entrance. The Pt wire tip was wound to form a spiral. A silicone disk was inserted between the Perspex rod and the Pt spiral, to add some flexibility and a piece of platinum foil, folded to the approximate shape of a disk, was added to the spiral to improve the electrical contact area with the grains.

To enhance electrolytic conductance (reducing $I \times R$ potential drop and heat dissipation) the Luer-Lock tip of the barrel was cut-off and eight extra perforations were drilled around the barrel near the tip. To avoid the loss of sample grains through the holes, the bottom of the modified barrel was lined with a circular piece of Perlon synthetic wool that covers all the holes, acting as a filter.

A modified syringe barrels with a Perlon plug inside was prepared and loaded with sample grains. The plunger with the Pt disk was inserted in one barrel at a time and firmly

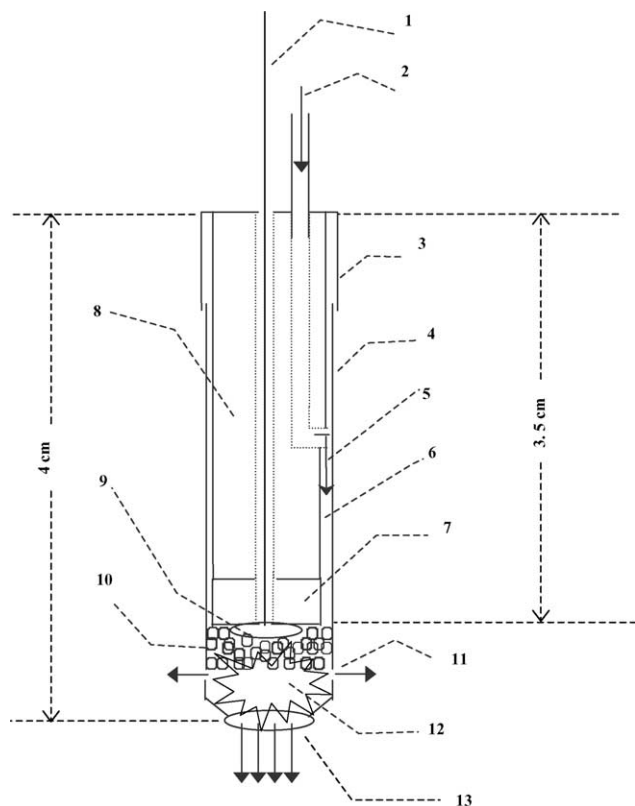

Fig. 1. Cut drawing schematized of anode semi-cell: (1) Pt wire (to establish electrical contact); (2) electrolytic solution inlet (i.d. = 1 mm); (3) teflon tape to seal the two parts; (4) 2.5 mL disposable syringe barrel of (i.d. = 0.8 cm and o.d. = 1.0 cm); (5) electrolytic solution pathway; (6) small furrow (length = 2 cm); (7) silicone disk (height = 0.8 cm); (8) acrylic rod piston (o.d. = 0.7 cm); (9) platinum disk (electrical contact with the sample); (10) sample material; (11) one of the eight electrolytic solution outlet holes (i.d. = 2 mm); (12) disk of Perlon tissue; (13) bottom electrolytic solution outlet (cut-off tip of syringe, i.d. = 0.5 cm).

pressed against the grains to establish electrical contact with the sample.

Some turns of Teflon tape wrapped around the Perspex rod served to adjust its diameter to assure pressure fitting into the barrel.

A laboratory clamp was used to hold this anodic semi-cell in a beaker containing a platinum wire as a cathode. The electrolyte was recirculated externally with an Ismatec Reglo peristaltic pump at a flow rate of 4.5 mL min^{-1} . A Gold Star DM-332 3 1/2 digit digital multimeter (in the 2 A range) was connected in series (Fig. 2) with a power source Phillips model 1512 (0–3.5 A, 0–35 V) that was adjusted to deliver 0.6 A.

The beaker and one loop of the pump tubing circuit were immersed in an ice-water bath to absorb the heat dissipated during electrolysis; this reduces HNO_3 volatilization and eliminates softening of the Tygon tubing used in the peristaltic pump (no expensive Viton tubes needed). Alternatively, to the water bath, higher concentrations of HNO_3 than 1.0 mol L^{-1} could be used to diminish $I \times R$ heat dissipation, but this would imply more reagent consumption, increased

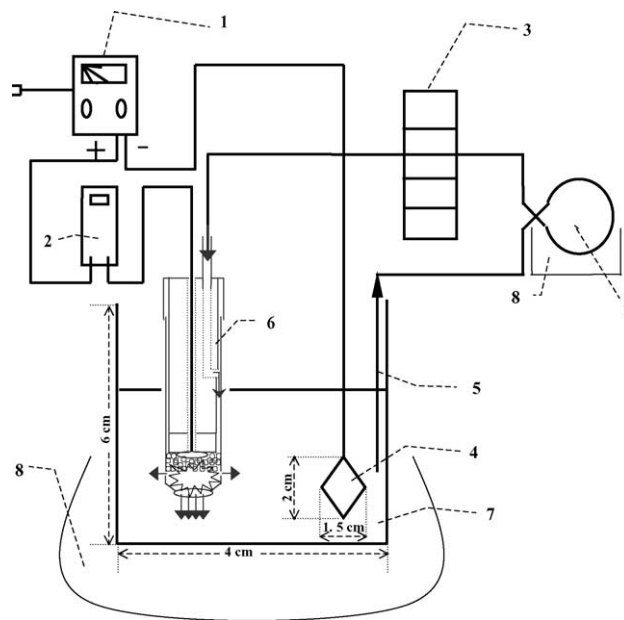

Fig. 2. Schematic drawing of the electrodisolution system: (1) dc-power source; (2) digital multimeter; (3) peristaltic pump (four-channel) with Tygon tubing (flow rate 4.5 mL min^{-1}); (4) cathode made from Pt wire; (5) direction of the electrolytic solution flow in the polyethylene tubing (i.d. = 1 mm); (6) anode semi-cell with the sample (Fig. 1); (7) beaker flask (capacity = 50 mL) with electrolytic solution (1 M HNO_3 , 15 mL); (8) ice-water baths; (9) loop of tubing inside an ice-water bath.

level of contaminants and problems with the operation of the manipulation (emitting vapour during electrolyze) and of the plasma torch.

A sequential Spectroflame Modula argon ICP spectrometer from SPECTRO Co. equipped with a Meinhard concentric nebulizer was used throughout. The instrumental parameters for ICP OES are given in Table 1.

Table 1
Instrumental parameters for ICP OES

rf power (W)	1200
Observation height (mm)	12
Integration time (s)	10
Aspiration solution rate (mL min^{-1})	1.5
Ar flow-rate coolant (mL min^{-1})	12
Ar flow-rate auxiliary (mL min^{-1})	1.2
Ar flow-rate carrier (mL min^{-1})	1.0

Element	Wavelength (nm)–LOD ($\mu\text{g mL}^{-1}$)
Fe	261.187–0.27
Cu	224.700–0.047
Mg	293.654–0.40
Mn	239.930–0.060
Cr	284.325–0.080
Ni	352.454–0.067
Zn	334.502–0.37
Pb	283.306 ^a –0.28
Ti	337.280–0.067
Al	236.705–5.13

LOD = $10 \times$ standard deviation of the background expressed as concentration in solution (limit of detection).

^a Background correction.

2.3.2. Electrodisolution procedure

A mass of about 100 mg of Al alloy sample, e.g. 50 meshes grains, was introduced in the modified barrel (Fig. 1) and placed on the Perlon wool. A series of syringe barrels with a sample inside would be prepared to speed up the change of samples.

The modified plunger with the platinum contact was inserted and this anode was connected to the electrodisolution system as already described (Fig. 2). The peristaltic pump was switched on (4.5 mL min^{-1}) and once the HNO_3 electrolyte solution (1.0 mol L^{-1}) started to flow through the sample, reaching the beaker, a current of 0.6 A was applied for 10 min. During electrodisolution, the formed metal ions are carried by the flow, first to the solution in the beaker, then to the external pumping circuit and back to the barrel. After switching the current off, the cell was maintained undisturbed, under electrolyte flow, for three more minutes. This was found efficient to assure chemical oxidation and dissolution of any metal deposited on the Pt cathode during electrolysis. The solution contained in the external tubing was pumped back to the flask and the anode semi-cell was removed. A rest period of about 20 min was applied to allow suspended gas bubbles to escape and insoluble Si to settle.

For Al alloys with high Si contents, it remained as suspended insoluble fraction and was filtered-off (medium porosity filter paper) before the determination by ICP OES. Dilution was necessary ($10\times$) when the determination of [Al] in the solution electrodisolved was made.

2.4. Quantification

Accurate weighing of the alloy sample is of limited utility for quantification because it is usually not possible to oxidize the grains completely, since some particle loss contact with the platinum disk. Also, as it is known, the electrodisolved mass cannot be accounted by the Faraday's law because of the occurrence of parallel reactions like gas evolution. However, certified reference materials with a composition similar to the unknown sample can be used for calibration purposes [6]. The chemical composition of the alloy can also be found using a multi-elemental technique for the determination of all elements of the alloy [7].

Aluminum is in large excess against other elements and its grade is characteristic for each alloy type. Therefore, the concentration of the minor element i ($\%E_i$) in the alloy can be obtained using the concentration ratio procedure [$\%E_i = C_i/C_{\text{Al}} \times (\% \text{Al})$] between C_i and C_{Al} (concentrations in electrolytic solution of the element i and the Al matrix) [20].

In this study, it is proposed to calculate $\%E_i$ by concentration ratio between C_i and ΣC_j (the sum of concentrations of all elements determined in the electrodisolved sample with exception of Al) and from the known sum of concentrations of these determined elements in the alloy ($\Sigma \%E_j$), when two or more elements are determined [$\%E_i = C_i/\Sigma C_j \times (\Sigma \%E_j)$]. The required known sum of concentrations can be achieved

either from certified reference materials or by one of their determination in an acid-totally dissolved sample with similar composition. Thus, the concentration of the Al did not need to be determined.

3. Results and discussion

3.1. Aluminum interference

The interference of an increasing concentration of aluminum in the matrix used for the determination of Fe, Cu, Mn, Mg, Cr, Ni, Zn, Pb and Ti by ICP OES was very small and similar for all elements. Low values for the highest Al concentration studied (8.2 mg mL^{-1}) was met, but that did not exceed 8%. At about 4 mg mL^{-1} , no interference was observed and near 2 mg mL^{-1} , a little higher result than the nominal was found (below 4%). Considering that in the practice the variation of the Al concentrations in the matrix resulting from the electrodisolution of the samples under consideration was in the explored range, it can be concluded that this interference could be disregarded. In other words, there was no need of a laborious fine matrix matching procedure in the preparation of the calibration and sample solutions for the ICP OES measurements.

3.2. Electrolytic dissolution

The average values and the relative standard deviation of three independent determinations of the elements Fe, Cu, Mn, Mg, Cr, Ni, Zn, Pb and Ti by ICP OES with total-acid dissolution of Al alloys and with electrodisolution are presented in Tables 2 and 3. For all of the elements dissolved both methods of quantification – using the concentration ratio procedure between C_i and C_{Al} or between C_i and ΣC_j – gave similar results. So, only results obtained by concentration ratio between C_i and ΣC_j are presented in tables. For these calculus all elements determined must be dissolved. For example, the residue obtained by electrodisolution of the B.C.S. 268/1 alloy was brown, not black as expected if only Si were present, and the determination indicated that Fe and Mn (Table 2) were not completely dissolved. When values were calculated without Fe and Mn, the obtained results for the other elements were better (E.d. in Table 2).

Values of relative standard deviations (R.S.Ds.) of three determinations in all electrodisolved Al alloys (certified or commercial samples) were lower than 10% for elements Fe, Cu, Mg, Mn, Cr (present only in one certified reference material), Ni, Zn and Ti with concentrations $>0.1\%$. For Pb, R.S.Ds. were higher than 10% due to the spectral analytical region and background correction.

For the lower concentrations of Mg in samples, observed in the alloys B.C.S. 182/2 and 380 (Table 2), higher results were obtained. Probably, this is because the spectral line of 293.654 nm was chosen taking into account a higher Mg concentration in most samples. Selection of a more sensitive

Table 2

Certified values, average and the relative standard deviation of three determinations by ICP OES (A.d.: total-acid dissolved; E.d.: electrolytically dissolved) and z-value to E.d.

Al alloy	Fe (%)	Cu (%)	Mn (%)	Mg (%)	Cr (%)	Ni (%)	Zn (%)	Pb (%)	Ti (%)
B.C.S. 182/2									
Certified	0.47 ± 0.02	0.045 ± 0.004	0.210 ± 0.01	0.075 ± 0.006		0.055 ± 0.005	0.100 ± 0.006	0.050 ± 0.003	0.11 ± 0.007
A.d.	0.464 ± 0.005	0.041 ± 0.001	0.210 ± 0.010	0.080 ± 0.001		0.059 ± 0.002	0.100 ± 0.002	0.042 ± 0.001	0.115 ± 0.001
E.d.	0.482 ± 0.004	0.040 ± 0.010	0.187 ± 0.002	0.120 ± 0.010		0.049 ± 0.003	0.106 ± 0.006	0.046 ± 0.007	0.096 ± 0.001
z (E.d.)	0.6	1.25	2.3	7.5		1.24	1.0	1.3	2.0
B.C.S. 216/2									
Certified	0.28 ± 0.01	4.56 ± 0.01	0.71 ± 0.01	0.75 ± 0.01		0.17 ± 0.01	0.20 ± 0.01	0.040 ± 0.004	0.037 ± 0.002
A.d.	0.263 ± 0.008	4.41 ± 0.05	0.712 ± 0.005	0.73 ± 0.07		0.16 ± 0.01	0.20 ± 0.02	0.032 ± 0.004	0.030 ± 0.002
E.d.	0.281 ± 0.016	4.57 ± 0.06	0.710 ± 0.021	0.74 ± 0.04		0.17 ± 0.01	0.21 ± 0.03	0.043 ± 0.010	0.047 ± 0.013
z (E.d.)	0.1	1.0	0	1.9		0	1.0	0.75	5.0
B.C.S. 263/2									
Certified	0.2 ± 0.01	0.019 ± 0.001	0.36 ± 0.01	4.67 ± 0.04	0.074 ± 0.004		0.056 ± 0.002		0.022 ± 0.002
A.d.	0.256 ± 0.002	0.017 ± 0.001	0.380 ± 0.001	4.49 ± 0.06	0.0803 ± 0.0001		0.056 ± 0.001		0.017 ± 0.001
E.d.	0.248 ± 0.007	0.021 ± 0.001	0.340 ± 0.001	4.69 ± 0.03	0.0686 ± 0.0011		0.059 ± 0.004		0.009 ± 0.001
z (E.d.)	1.2	1.5	2.4	0.5	1.35		1.5		6.7
B.C.S. 380									
Certified	1.15 ± 0.03	0.90 ± 0.02	0.018 ± 0.002	0.18 ± 0.01		0.91 ± 0.02	0.011 ± 0.001		0.22 ± 0.01
A.d.	1.10 ± 0.04	0.87 ± 0.01	0.015 ± 0.002	0.184 ± 0.006		0.86 ± 0.02	0.009 ± 0.001		0.217 ± 0.006
E.d.	1.10 ± 0.01	0.91 ± 0.02	0.0085 ± 0.0004	0.220 ± 0.010		0.94 ± 0.02	0.011 ± 0.002		0.20 ± 0.02
z (E.d.)	1.7	0.5	4.75	4.0		1.5	0		2.0
B.C.S. 268/1									
Certified	0.47 ± 0.01	1.35 ± 0.02	0.24 ± 0.01	0.49 ± 0.02		0.16 ± 0.01	0.028 ± 0.001	0.028 ± 0.002	0.008
A.d.	0.44 ± 0.03	1.36 ± 0.01	0.24 ± 0.01	0.47 ± 0.01		0.15 ± 0.01	0.024 ± 0.001	0.023 ± 0.001	<0.008
E.d.	0.090 ± 0.009	1.67 ± 0.01	0.13 ± 0.00	0.64 ± 0.01		0.16 ± 0.01	0.035 ± 0.002	0.038 ± 0.010	<0.001
E.d. (without Fe and Mn in calculus)		1.35 ± 0.01		0.51 ± 0.01		0.14 ± 0.01	0.028 ± 0.001	0.040 ± 0.009	<0.001
z (E.d.)	–	0	–	1		2.0	0	6.0	

Table 3
Average and relative standard deviations of three determinations by ICP OES (A.d.: total-acid dissolved; E.d.: electrolytically dissolved)

Al alloy	Fe (%)	Cu (%)	Mn (%)	Mg (%)	Cr (%)	Ni (%)	Zn (%)	Pb (%)	Ti (%)
T	A.d.	1.09 ± 0.17	0.0091 ± 0.0009	1.18 ± 0.01	0.0056 ± 0.0007	0.90 ± 0.02	0.0140 ± 0.0001	0.0145 ± 0.0001	<0.0007
	E.d.	1.17 ± 0.01	0.0019 ± 0.0003	1.16 ± 0.01	<0.0012	0.86 ± 0.01	0.012 ± 0.001	<0.004	<0.001
2024	A.d.	3.17 ± 0.06	0.34 ± 0.02	1.54 ± 0.01	0.036 ± 0.002	0.043 ± 0.003	0.57 ± 0.03	0.0144 ± 0.0023	<0.0007
	E.d.	3.29 ± 0.08	0.34 ± 0.02	1.53 ± 0.09	0.035 ± 0.011	0.036 ± 0.003	0.56 ± 0.06	<0.004	<0.001
7075	A.d.	2.28 ± 0.09	0.060 ± 0.002	2.41 ± 0.01	0.30 ± 0.01	0.015 ± 0.002	4.79 ± 0.20	0.022 ± 0.002	<0.0007
	E.d.	2.26 ± 0.07	0.045 ± 0.007	2.49 ± 0.19	0.25 ± 0.02	0.011 ± 0.002	4.78 ± 0.23	<0.004	<0.001
6061	A.d.	0.232 ± 0.001	0.041 ± 0.002	0.85 ± 0.02	0.099 ± 0.001	0.0018 ± 0.0003	0.019 ± 0.000	<0.003	0.0089 ± 0.0001
	E.d.	0.245 ± 0.006	0.033 ± 0.001	0.87 ± 0.01	0.090 ± 0.001	<0.001	0.017 ± 0.001	<0.004	<0.001

spectral line with a more linear answer for minor concentrations of Mg may eliminate this error source.

Significance Tests denoted by z are common as statistical tests for comparing sets of data with the certified value of the reference materials. Values of z were calculated and are given in Table 2. If the value of z falls within the region of the normal curve at 95% confidence level, i.e. $z < 1.96$, the mean concentrations of the element determined and the reference materials certified are not significantly different. The calculated values of z (Table 2) for the elements Fe, Cu, Mg (concentration >0.2%), Cr, Ni and Zn do not exceed the tabulated z -value of 1.96. Thus, a good agreement was obtained between the results for those electrodisolved elements determination and the values of the certified reference materials. For Ti with concentration >0.1%, z -value was 2.0. It is near z at 95% confidence level (1.96) and the analytical results can be considered. For Pb, z -value is good when concentration >0.04%, but the R.S.Ds. were higher than 10% as mentioned above. Then, the determination of Pb, in the concentration level of the sample here analyzed it is not recommended.

The results for the element Mn were lower than those expected for the majority of the samples and higher inaccuracies were eventually observed for Fe and Mn in B.C.S. 268/1, as mentioned above. Those elements in that alloy have the dissolution incomplete, probably because the electrodisolution depends on the phases where Fe and Mn are present in the Al alloy. Therefore, the determination by ICP OES of Mn in electrodisolved Al alloys is not recommended, nor it is for those elements, which are present in lower concentrations (Pb, Ti).

4. Conclusion

In this work, the electrolytic dissolution of aluminum in batch and alloys in chip or grain form proved to be a simpler, faster and cleaner method (no projects solutions) than the conventional acid dissolution procedure, with comparable effectiveness. After electrodisolution of a small amount of the sample, ICP OES could determine minor metal constituents of alloys [Fe, Cu, Mg, Cr, Ni, Zn and Ti (>0.1%)] as well as aluminum.

For metal alloys exhibiting unselective anodic oxidation of the components to be measured, the method proposed here might possibly be adapted to on-line operation with a mixing chamber before the torch of a simultaneous reading ICP OES. The method is not restricted to aluminum alloys. The search for an electrolyte that prevents passivation deserves to be considered.

The method described here for electrodisolution of Al alloys is slower than procedures on-line described in the literature [5,6]. But, these procedures were restricted to samples in the form of solid blocks or plates, with at least one polished flat face. Thus, the capability of dealing with samples in various forms frequently used in practice like chips, turnings, wire sponges or coarse powders (eventually, fine compacted

powders) is a definite advantage over the previously described forms of flow electrodisolution.

References

- [1] R.C. Chirnside, H.J. Cluley, P.M.C. Proffitt, *Analyst* 82 (1957) 18.
- [2] M. Hiraide, P. Tschöpel, T. Günther, *Anal. Chim. Acta* 186 (1986) 261.
- [3] H. Bergamin Fo, F.J. Krug, E.A.G. Zagatto, E.C. Arruda, C.A. Coutinho, *Anal. Chim. Acta* 190 (1986) 177.
- [4] H. Bergamin Fo, F.J. Krug, B.F. Reis, J.A. Nóbrega, M. Mesquita, I.G. Souza, *Anal. Chim. Acta* 214 (1988) 397.
- [5] D. Yuan, X. Wang, P. Yang, B. Huang, *Anal. Chim. Acta* 243 (1991) 65.
- [6] D. Yuan, X. Wang, P. Yang, B. Huang, *Anal. Chim. Acta* 251 (1991) 187.
- [7] I.G. Souza, Fo. Bergamin, F.J. Krug, J.A. Nóbrega H, P.V. Oliveira, B.F. Reis, M.F. Giné, *Anal. Chim. Acta* 245 (1991) 211.
- [8] I.G. Souza, Fo. Bergamin, F.J. Krug, B.F. Reis, P.V. Oliveira, J.A. Nóbrega, *Quim. Nova* 15 (3) (1992) 204.
- [9] J.B.B. Silva, M.B.O. Giacomelli, A. Lehmkuhl, A.J. Curtius, R.R.U. Queiroz, I.G. Souza, *Quim. Nova* 22 (1) (1999) 18.
- [10] A.P.G. Gervásio, C. Luca, A.A. Menegário, H. Bergamin Fo, B.F. Reis, I.G. Souza, *Quim. Nova* 22 (5) (1999) 669.
- [11] A.P.G. Gervásio, C. Luca, A.A. Menegário, B.F. Reis, H. Bergamin Fo, *Anal. Chim. Acta* 405 (2000) 213.
- [12] J.B.B. Silva, I.G. Souza, A.P. Gervásio, *Quim. Nova* 23 (2) (2000) 244.
- [13] A.P. Packer, A.P.G. Gervásio, C.E.S. Miranda, B.F. Reis, A.A. Menegário, M.F. Giné, *Anal. Chim. Acta* 485 (2003) 145.
- [14] C.A. Giacomozzi, R.R.U. Queiroz, I.G. Souza, J.A.G. Neto, J. Autom. Methods Manage. Chem. 21 (1) (1999) 17.
- [15] J.B.B. Silva, M.B.O. Giacomelli, I.G. Souza, A.J. Curtius, *Talanta* 47 (1998) 1191.
- [16] I.I. Kusel'man, L.A. Malykhina, V.A. Kozhanov, *Ind. Lab.* 56 (12) (1990) 1440.
- [17] T.A. Coutinho, *Análise e prática. Metalografia de não-ferrosos*, Edgard Blücher, São Paulo, 1980.
- [18] T. Grigoletto. Ph.D. Thesis (unpub.), Instituto de Química, Universidade de São Paulo—USP, 2001.
- [19] R.M. Barnes, L. Fernando, L.S. Jing, H.S. Mahanti, *Appl. Spectrosc.* 37 (4) (1983) 389.
- [20] A.F. Ward, L.F. Marciello, *Anal. Chem.* 51 (13) (1979) 2264.