

STUDY OF THE INACTIVE LAYER OF A GERMANIUM DETECTOR: EXPERIMENTAL AND MONTE CARLO SIMULATION TREATMENTS

Juan Y. Zevallos-Chávez¹, Carlos Augusto Pires¹, Frederico Antonio Genezini²,
Guilherme Soares Zahn¹ and Manoel Tiago F. da Cruz³

¹ Instituto de Pesquisas Energéticas e Nucleares (IPEN / CNEN - SP)
Av. Professor Lineu Prestes, 2242
05508-000 São Paulo, SP
juan@if.usp.br

² Centro Regional de Ciências Nucleares (CRCN/CNEN/PE)
Av. Professor Luiz Freire, 1
50740-540 Recife, PE

³ Instituto de Física da Universidade de São Paulo
Travessa R, 187
05508-900 São Paulo, SP

ABSTRACT

The detection efficiency of a Germanium detector was measured in the energy range of 80 keV up to 1 MeV. A model function to fit the efficiency data was used, containing an absorbing window factor. The results were compared with a Monte Carlo simulation of the photon interactions where, the nominal dimensions were varied in order to check the low-energy behavior of the efficiency curve. The Monte Carlo results showed to be in good agreement with the experimental ones when the nominal dimensions of the crystal, except for its dead layer thickness, were used. This difference in the dead layer was attributed to its non-uniformity.

1. INTRODUCTION

An important step in gamma spectroscopy measurements is the efficiency calibration of the acquisition system. Such calibration is made through measurements with standard sources, in the desired geometry, for posterior fitting using a functional form to model the detecting efficiency. In the literature there are many functions suggested for this purpose [1], however none proves suitable to describe the detection efficiency in the region of low energy photons; this is due to an interference produced by the inactive parts of the detector, as the dead layer of the semiconductor material, electric contacts and the Aluminum cup holder, producing an attenuation effect which is increasingly important when the photon energy decreases.

In order to elucidate this phenomenon, the efficiency of a p-type Germanium coaxial detector was determined by experimental measurements and simultaneously by means of Monte Carlo simulations using the EGS4 code [2], in the energy range from about 80 keV up to 2 MeV. The comparison between the experimental curve and the simulated data shall indicate details about the real detector's geometry, supplying information on the absorbing layer, which is a fundamental parameter in the low-energy part of the efficiency curve.

2. EXPERIMENTAL EFFICIENCY

2.1. Measurements

The measurements were made using an 89 cm³ p-type Germanium coaxial detector. The Germanium crystal has 47.0 mm of diameter and 54.4 mm of length. The standard calibration sources were positioned at a distance of 14.5 cm from the end cap of detector, and a support made of lucite was used to hold them in the symmetry axis of the detector. The standard calibration sources used were ⁶⁰Co, ¹⁵²Eu, ¹³³Ba, ¹³⁷Ba and ¹⁰⁹Cd.

The electronic system associated to the detector was composed by a linear amplifier in inhibit mode and an analogical multichannel analyzer.

2.2. Efficiency function

The function chosen to fit the absolute efficiency data is composed by the sum of two exponentials, both multiplied by a third exponential. The function is shown below:

$$\epsilon(E) = [P_1 \exp(P_2 E) + P_3 \exp(P_4 E)] \exp\left[-\frac{\mu}{\rho} P_5 E\right] \quad (1)$$

being P_i the parameters to be fitted, μ the attenuation coefficient of Germanium which depends on the photon energy and ρ the density of Germanium.

In the first stage of this work the parameter P_5 , which appears in the third exponential, is related to the value of the Germanium dead layer thickness. Because the attenuation effect is not only due to the Germanium, the equation above must be written as :

$$\epsilon(E) = [P_1 \exp(P_2 E) + P_3 \exp(P_4 E)] \exp\left[-\sum_{j=5}^n \frac{\mu_j}{\rho_j} P_j E\right] \quad (2)$$

where P_j is related to the thickness of the "j" material producing attenuation effects. Using the equation 2, we also considered in the fit calculation the contribution of Aluminum layers.

3. MONTE CARLO SIMULATION

In order to calculate the detection efficiency curve several simulations were done using the EGS4 code[2], which takes into account the transport of photons and electrons in matter.

Both the sampling of the photon source and the geometry were simulated as closely as possible to reproduce the experimental setup.

3.1 Sampling the source of photons

The source was considered as a point emitting photons in the energy range from about 80 keV up to 1 MeV. The source was collimated to a planar circle with a radius equal to that of the end cup detector. The number of initial photons generated in the simulations was 5×10^6 .

3.2 Modeling the geometry

The geometry was modeled following the nominal manufacturer values giving emphasis to the inactive parts of the detector which produce the attenuation effects. See Fig 1.

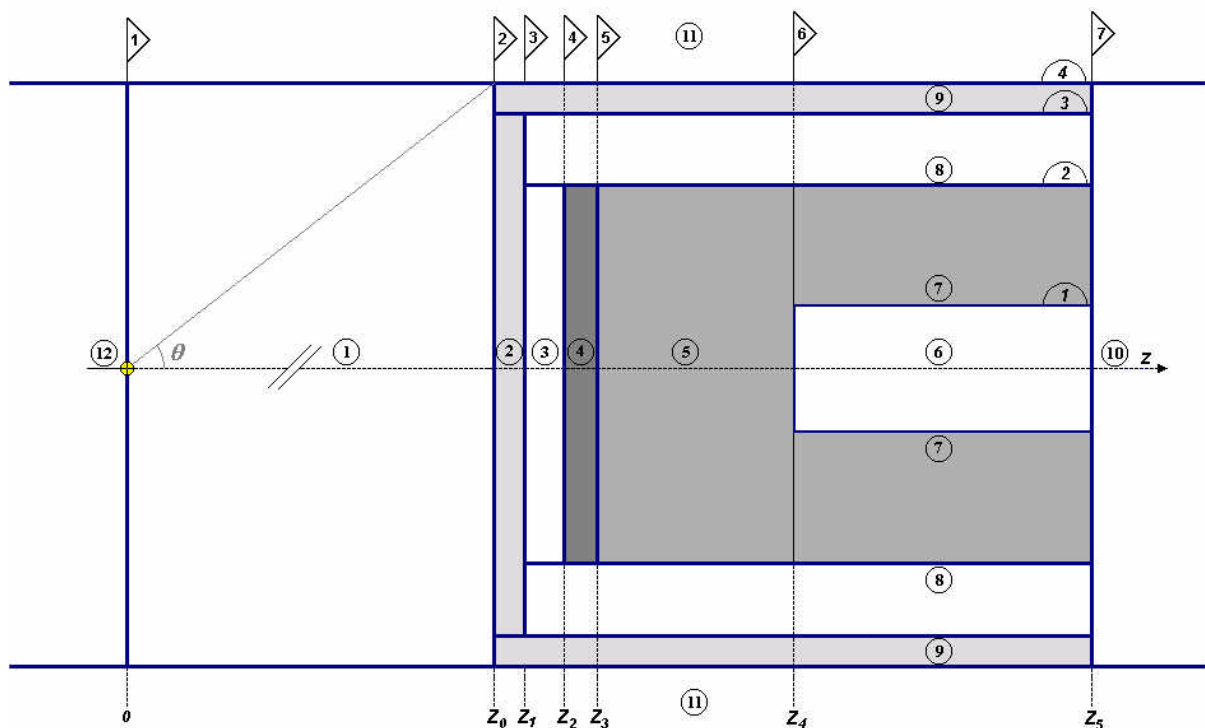

Fig. 1. Geometry modeled for the 89 cm^3 p-type coaxial detector. In the figure θ is the angle used to sampling the photons source. The circles and triangles indicate geometrical regions and z-surfaces, respectively; the half-circles indicates cylindrical surfaces.

The numbers in Fig.1 inside the circles, represent the geometrical regions defined in the simulation. The vacuum regions were identified by the numbers 1, 3, 6, 8, 10, 11 and 12. The Aluminum by the numbers 2 and 9 and the Germanium by the numbers 4 (inactive part), 5 and 7. The source was located in the (0,0,0) coordinates. In the figure the z planes were also identified by numbers inside the triangles. Finally, the source-to-detector distance was defined as the distance between the planes $Z = 0$ and $Z = Z_0$.

Some changes were done in the inactive Germanium and Aluminum thicknesses, in order to observe the behavior of the efficiency curve in the low energy part.

4. RESULTS

4.1. Experiment

The fitted values for the efficiency model function, equation(1), are listed in table 1. From P_5 , the inactive Germanium thickness was 1.7 mm. In addition, the equation (2) was also used to include the attenuation effect due to the Aluminum cup holder but no change was noticed for the fitted Germanium dead layer thickness.

Table 1. Fitted parameters P_i .

Parameter	value
P_1	$7.86 \times 10^{-3}(52)$
P_2	$-6.74 \times 10^{-1}(54) \text{ MeV}^{-1}$
P_3	$4.32 \times 10^{-2}(27)$
P_4	$-6.14(30) \text{ MeV}^{-1}$
P_5	$9.15 \times 10^{-1}(63) \text{ cm}^2 \cdot \text{g}^{-1}$

4.2. Simulation

The geometry modeled using the nominal values [3] for the inactive detector parts, produce simulation values that are in good agreement with the experimental efficiency (see Fig.2). In order to compare experimental and simulated data both were normalized to the efficiency value at 1 MeV. The simulated values were calculated with uncertainty lower than 0.1 %.

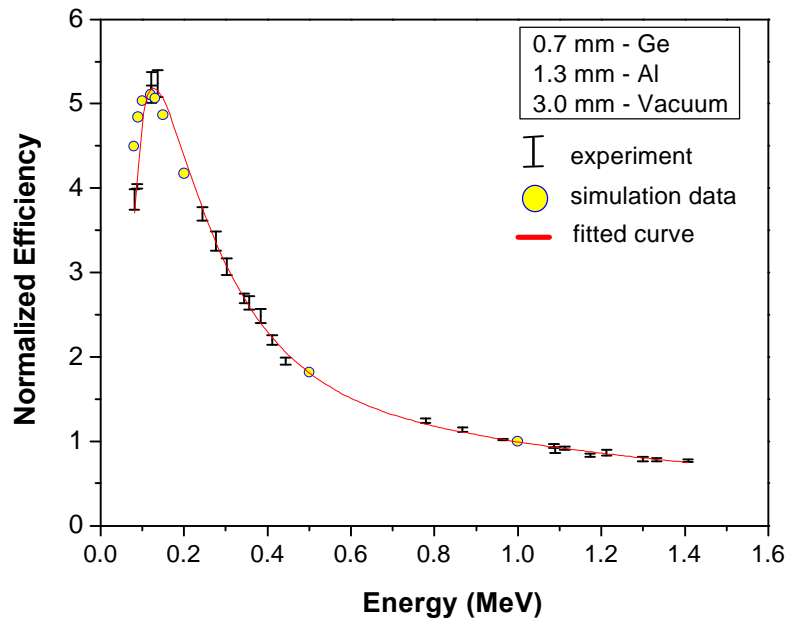

Fig. 2. Comparison between the experimental efficiency curve and simulated data.

Other simulations were also done in which the nominal dimensions are allowed to vary (0.7 mm to 1 mm for the inactive Germanium thickness and 1.3 mm to 2 mm for the Aluminum cup holder thickness), but a less adequate agreement was observed.

5. CONCLUSIONS

The experimental result obtained for the Germanium dead layer thickness, 1.7(1) mm, and the nominal value, 0.7 mm, are in disagreement. Therefore, the experimental procedure used in this work proved to be inadequate to perceive the variations in the dead layer thickness. In order to elucidate this issue, a different experiment should be proposed, which could allow the measurement of the dead layer in different positions over the surface of the detector's crystal.

However the simulation model used for the detector geometry is satisfactory, some tuning is still necessary mainly in the low energy photon range (less than 100 keV). Because the attenuation effect is more important when the photon energy decreases, a better Monte Carlo simulation model for the inactive parts of the detector is necessary. Finally, in order to elucidate this fact a new model is being prepared, in which a special care is taken to the non-uniformity of the dead layer.

ACKNOWLEDGMENTS

The authors would like to thank LEN/IPEN for the use of facilities. Dr. Zevallos-Chávez would like to acknowledge CLAF-CNPq for the financial support.

REFERENCES

1. G. F. Knoll, *Detection Radiation and Measurements*, John Wiley 3rd Ed. NY, (1999).
2. W. R. Nelson, H. Hirayama, D. W. O. Rogers, *The EGS4 Code System*, Stanford Linear Accelerator (1985).
3. ORTEC, *GEM Series Detector – Operating and Service Manual*, EG&G ORTEC, Oak Ridge, USA (1995).