

TWG 1 Members

PRODUÇÃO TÉCNICO CIENTÍFICA
DO IPEN
DEVOLVER NO BALCÃO DE
EMPRESTIMO

— **Mario Carelli***** Westinghouse Electric Co.

— **John Cleveland** International Atomic Energy Agency

— **Michael Corradini** University of Wisconsin

— **Dario Delmastro** Centro Atomico Bariloche

— **John C. (Jack) DeVine*** Polestar

— **David Diamond** Brookhaven National Laboratory

— **Ken Hedges*** Atomic Energy of Canada Limited

— **Phillipe Laurent** Framatome - ANP

— **Yoon Young Lee** DHICO

— **Phillip MacDonald**** INEEL

— **Yoshiaki Oka** University of Tokyo

— **Akira Omoto** Tokyo Electric Power Company

— **Jong Kyun Park** Korean Atomic Energy Research Institute

— **Noval Smith** Virginia Power Co.

— **Antonio Teixeira E SILVA** IPEN/CNEN

— **Alfredo Vasile** Commissariat a l'Energie Atomique

— **Gary Was** University of Michigan

* **Co-chair** ** **Technical Director** *** **Presenter**

Introduction

- This Technical Working Group was charged with the identification and evaluation of advanced water-cooled reactor concepts.
 - The initial activity was the assessment and “screening for potential” of candidate systems.
 - Advanced water-cooled reactor concepts were identified via a formal DOE “Request for Information” (RFI) issued in April 2001.
 - This process resulted in submittal of 30 advanced water reactor concepts by researchers and industry experts in Argentina, Brazil, Canada, France, Italy, Japan, Korea, and the U.S.
 - In addition, the technical working group itself developed information on eight concepts, yielding a total of 38 concepts for evaluation.
 - The technical working group consolidated all but one of the 38 reactor and fuel cycle concepts into nine distinct concept sets, based on their key common features.
 - The technical working group then conducted a preliminary evaluation of these nine sets in order to determine their potential to achieve the Generation IV goals.
-

Evaluation Process

Master Table. A “Master Table” was constructed with the main characteristics of each concept, e.g. reactor size, plant design approach, coolant and moderator and their physical state, cycle, thermal efficiency, reactivity control, primary system layout, etc.

Concept Grouping.

Sub-group evaluation. Each concept set was assigned to a sub-group of the technical working group consisting of two or three technical experts. The sub-team examined the information available, obtained additional information as needed, and assembled a preliminary assessment.

Full team evaluation. The entire technical working group evaluated and, in large measure, reached consensus on the evaluation of each concept set:

- Assessment potential, with respect to each Generation IV goals and criteria.
- Assessment of individual reactor concepts within the set, in areas where there were significant differences from the overall set.
- Identification of main research needs.
- Scoring, by producing a scorecard showing in graphical form the potential of the set against each of the Generation IV goals.

Evaluation Process (continued)

Documentation. The technical working group evaluation for each concept set was documented, in detail, via compilation of the concept descriptive material and summaries of each set evaluation, including the primary R&D requirements, tabulation of major advantages and disadvantages, factors influencing scoring, and completed scorecards. Each of these compilations was produced in the form of an appendix to the initial roadmap report.

Screening for Potential. This final screening was accomplished, via extensive team discussion and consideration of previous evaluation work, during the August technical working group meeting.

Integrated Primary System Reactors

- *These light water reactor concepts are characterized by a primary system that is fully integrated in a single vessel, which makes the nuclear island more compact and eliminates the possibility of large releases of primary coolant.*
- *The emphasis is on utilization of existing LWR technology, modularity, elimination of accident initiators, and passive systems to cope with the consequences of accident events.*
- *Of the three major Generation-IV high-level goals, this class of reactors mainly addresses the potential for superior safety and good economics.*
- *On the other hand, resource utilization and proliferation resistance are rated as comparable (or just slightly better) than current LWRs with similar fuel cycles.*
- *At this point the key R&D issues for these systems appear to be the economic viability of a modular design approach as well as the reliability and design of the in-vessel components.*

IRIS Vessel Layout (300 MWe)

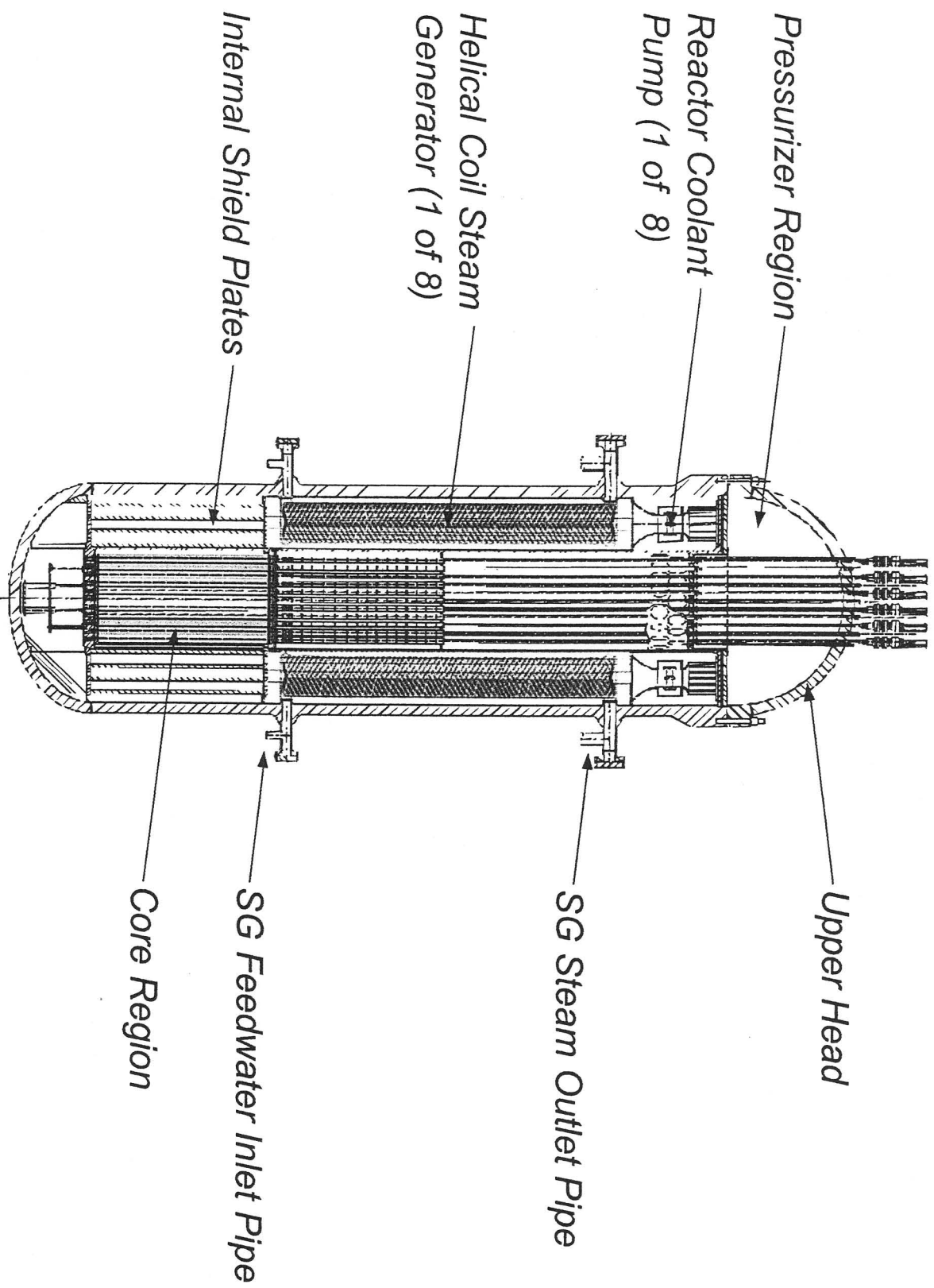

Advanced Loop Pressurized Water Reactors.

- The common innovative characteristic of these reactor designs is the use of a safeguard vessel (or series of vessels and pipes) that envelopes the whole primary system for mitigation of primary system component failure.
- Moreover, the adoption of the additional vessel enables elimination of some safety systems.
- This reactor concept offers potential for superior safety compared with the reference LWRs.
- However, issues to be resolved include reliability and maintenance of the primary system components that are not easily accessible, and impact of the additional vessel on the capital cost.

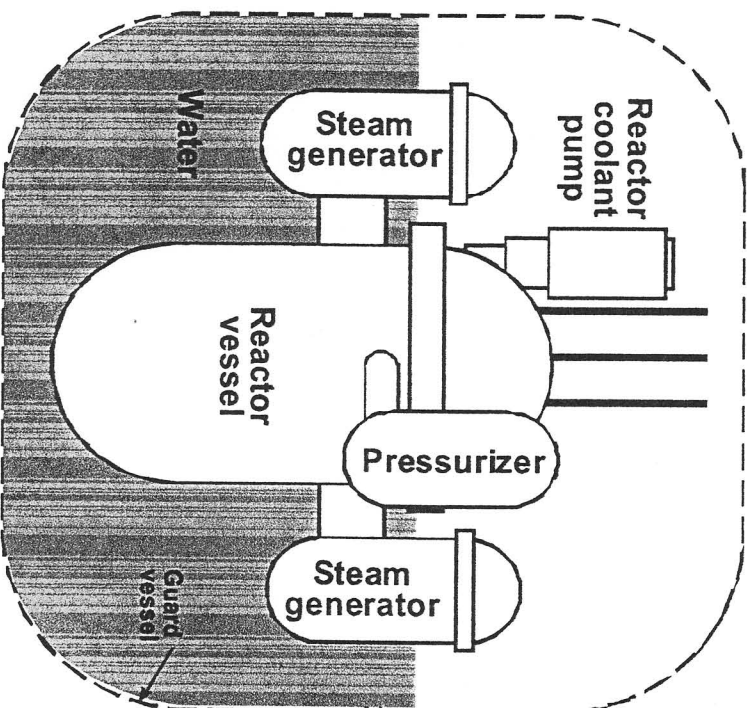

Simplified Boiling Water Reactors

- *These are various size boiling water reactors with natural circulation in the core region, no re-circulation pumps, and, in most cases, highly passive decay heat removal systems.*
- *With one exception (the SMART concept) the concepts within this group are all founded on existing and proven BWR technology and do not need extensive R&D for their deployment.*
- *They feature various design improvements intended to provide economic or other advantages.*
- *At this point the key R&D issue for these systems appears to be the demonstration of their economic values relative to other designs.*

Schematic of Passive Safety Systems for the ESBWR

Passive Containment Cooling System (PCCS) and

Gravity Driven Cooling System (GDCCS) → Isolation Condenser System (ICS)

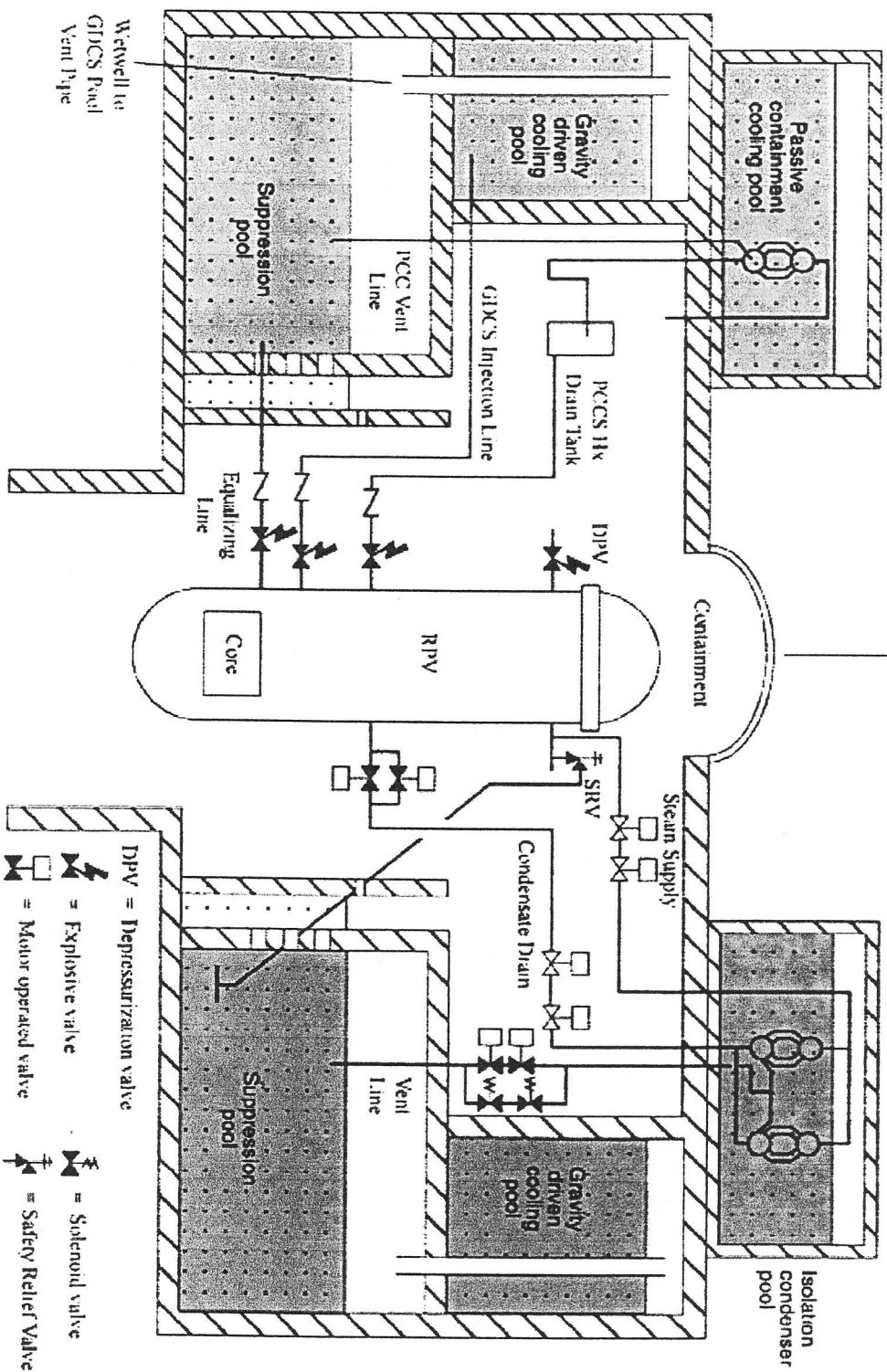

- DPV = Depressurization valve
- Explosive valve
- Motor operated valve
- Solenoid valve
- Safety Relief Valve

Pressure-Tube Reactors

- This concept set is based on the CANDU design.
- The emphasis is on improving the economics by:
 - replacing the heavy water coolant with light water,
 - moderately increasing the thermal efficiency,
 - simplifying and reducing the size of the nuclear island, and
 - use of thorium fuel.

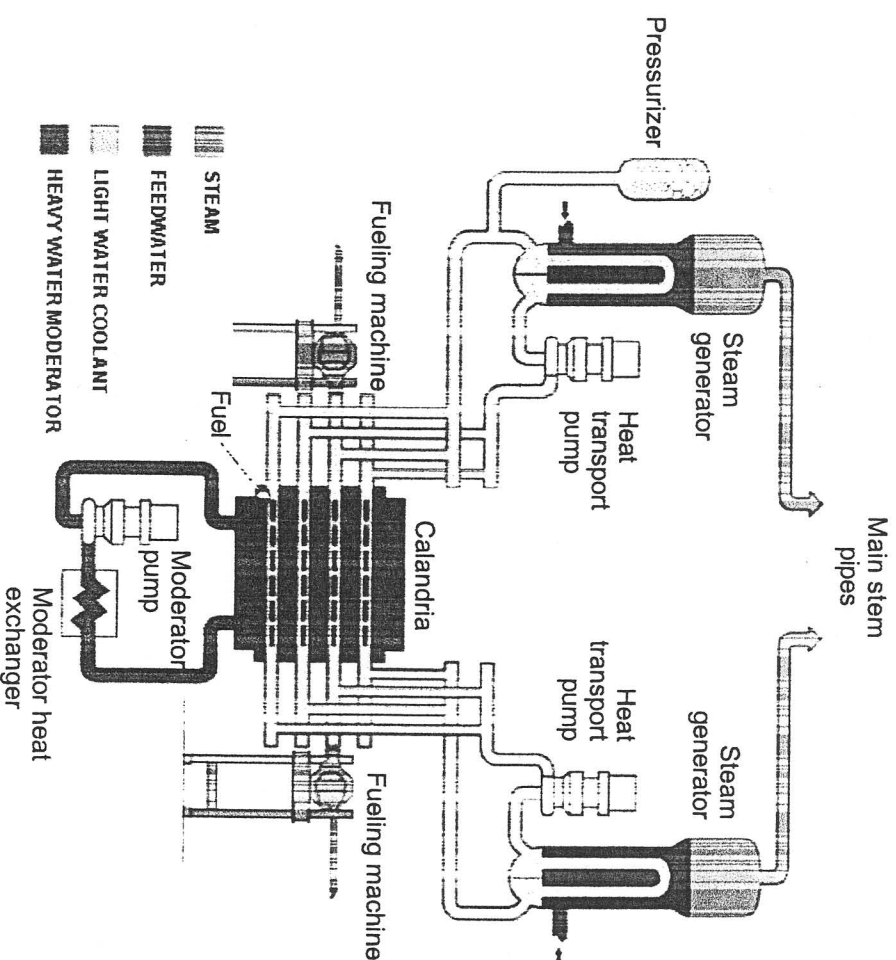

Supercritical Water-Cooled Reactors

- *The unique thermo-physical properties of supercritical water offer potential for designing nuclear reactors with significantly higher thermal efficiencies (40-45% versus the current 33-34%) and considerable plant simplification, compared to the ALWR.*
- *However, to make such systems technologically feasible:*
 - *advances are required in high-temperature materials to improve corrosion, stress corrosion cracking, and wear resistance,*
 - *in neutronics to improve fuel-cycle versatility with these advanced materials, and*
 - *in neutronics and thermal-hydraulics to insure an acceptable level of safety and stability.*

High-Conversion Reactors

- *These are LWRs with a tighter fuel lattice and less moderator and, therefore, a fast spectrum with greatly increased fuel utilization.*
- *Since uranium resources will become scarce in a nuclear economy, this concept set might become very important in the future.*
- *However, there are key R&D issues to be addressed, including:*
 - *neutronic stability of the core (e.g., negative void reactivity coefficient),*
 - *development of appropriate fuel cladding and core internals structural materials,*
 - *demonstration of effective coolability of tight cores, and*
 - *development of suitable proliferation resistant fuel reprocessing techniques to take advantage of the increased production of fissile material.*

Pebble-Fuel Reactors

- *The emphasis in this class of reactors is on passive safety: both shutdown and decay heat removal.*
- *The fuel temperatures are significantly reduced during operation.*
- *However, the fuel fabricability and reliability in a water environment needs to be demonstrated.*

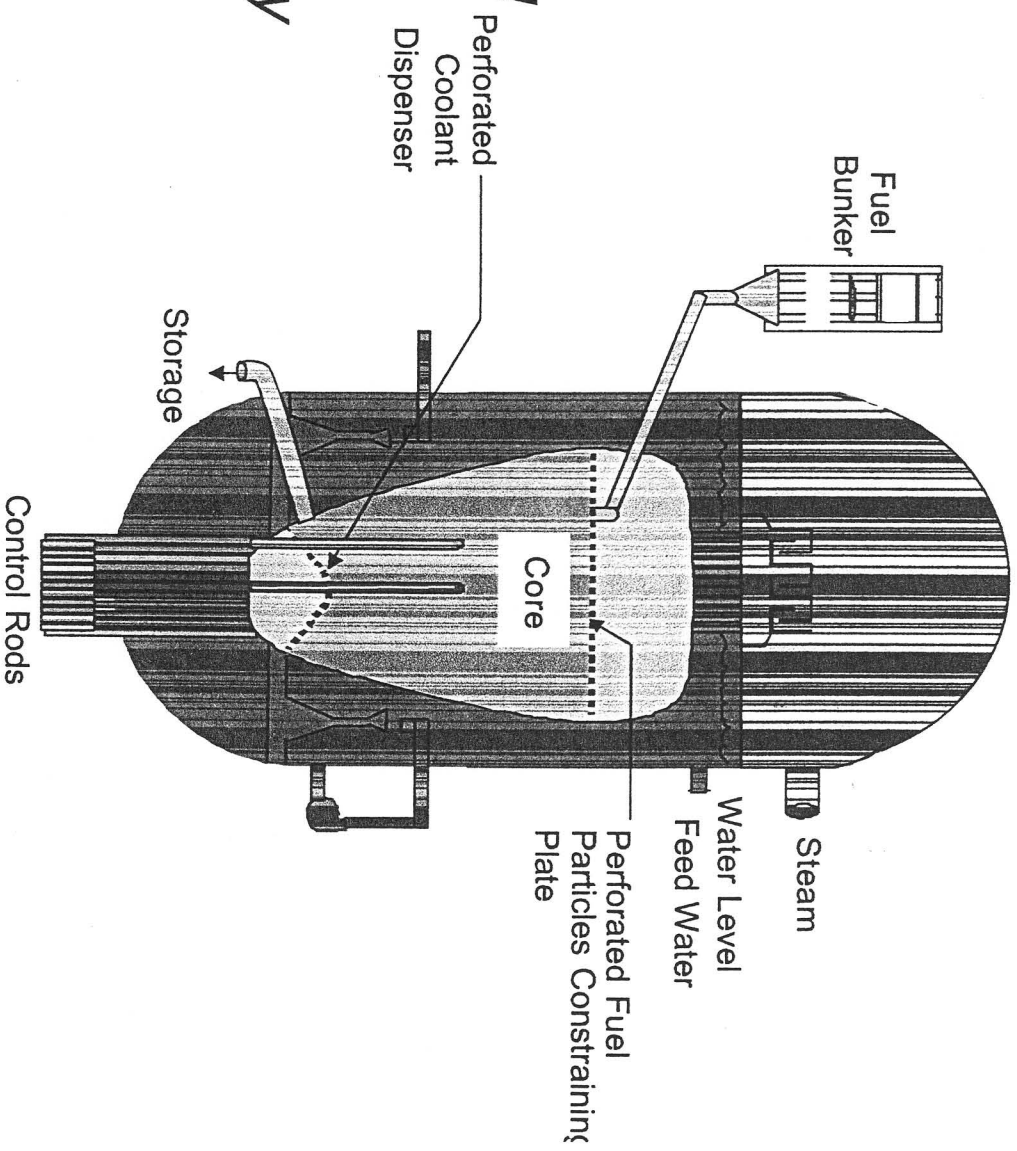

ALWRS with Thorium-Based Fuels

- *The significant advantages of the once-through thorium cycles with respect to proliferation resistance and waste form stability are very attractive to society as a whole, but provide little economic incentive to the current nuclear fuel industry.*
- *The energy resource sufficiency advantage of the U-233/Th-232 light water breeder reactor fuel cycle is currently outweighed by reliability and cost issues.*
- *However, further out in the future our low cost uranium supplies will become depleted and the thorium fuel cycles will eventually become cost effective.*

ALWRS and CANDU Reactors with Dry Recycling of Spent LWR Fuel

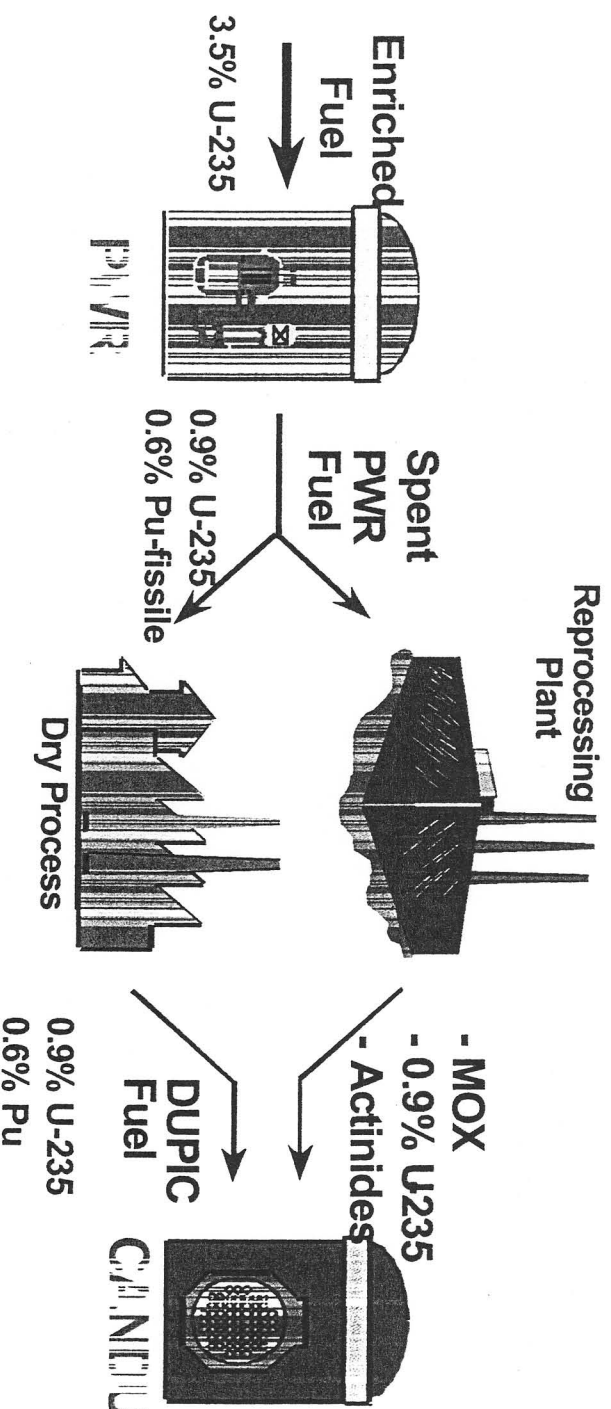

- These technologies have significant potential for reducing spent fuel volumes and increasing fuel utilization.
- Key R&D issues that are identified for this fuel cycle include:
 - cost effective fabrication processes and equipment, and
 - adequate solutions for capture and immobilization of the volatile fission products that are released during the recycling process.

Summary

- The 38 reactor and fuel cycle concept submittals in the area of water-cooled nuclear systems were grouped into nine concept sets.
- All nine concept sets were retained for further assessment in the second phase of the Generation IV Roadmap.
- One individual concept was discarded, the U-Np-Pu cycle was deemed unfeasible for mass production of electricity because of the scarcity of neptunium supplies and because of the high value of neptunium for alternative uses.
- Several R&D needs were identified:
 - fuel cladding and structural materials for higher burnup and temperature applications,
 - reactor components for infrequent maintenance,
 - the quantitative assessment of the benefits of small-power modular designs, and
 - the updating/validation of existing predictive tools for the expanded design envelope of the advanced reactors.
- The next step for the Advanced-Water-Cooled-System Technical Working Group is to develop quantitative assessments of the more promising concepts or concept groups and to clearly define the scope of the needed R&D.



Generation IV Water-Cooled Reactor Concepts

**Technical Working Group 1 - Advanced Water-
Cooled Reactors**

**Generation IV Roadmap Session
ANS Winter Meeting Reno, NV
November 13, 2001**