

# Laser Power-meter Employing Neutral Density Filters

M. Duarte & M. M. F. Vieira

Instituto de Pesquisas Energéticas e Nucleares, PO Box 11049, São Paulo,  
SP, Brazil, 05422-970

(Received 28 October 1996; revised 15 December 1996; accepted 27 February 1997)

## ABSTRACT

*The design of a laser power-meter based on the photoacoustic effect is described, where a commercial metallic-type neutral density filter is employed as the absorbing material. Filters of different optical densities can be used, thus covering a very broad laser power-range. The power meter may also be used to measure the luminous power from spectral lamps, since the neutral density filter is a very reliable and practical substitute for carbon-black. © 1997 Elsevier Science Ltd.*

## 1 INTRODUCTION

Laser power-meters are of fundamental importance for optical laboratories. There is a large variety of them offered in the market, but it is difficult to find a general-purpose one, presenting a broad spectral response range and allowing direct power incidence. The simplest ones are based on calorimetric effects which operate by measuring absorbed thermal energy. There are several laws concerning the measurement of this absorbed thermal energy. For this reason, this kind of laser power-meters has been the subject of several publications.<sup>1–7</sup> Although these meters are different, all of them have two characteristics in common: simplicity and low cost.

In this paper, we described a laser power-meter based on the photoacoustic effect (PA), where the absorbing element (the source of thermal energy production) is a commercial neutral density filter. There are some power meters based on the photoacoustic effect described in the literature.<sup>1–5</sup> These meters present the advantage that the equipment

required, such as lock-in amplifiers and choppers, are commonly available in optical laboratories. The laser power-meter described in this paper provides the additional advantage of using commercial neutral density filters as the absorbing material, rendering it more practical and reliable.

## 2 FUNDAMENTALS

The basic principle of the photoacoustic effect is simple to understand.<sup>8</sup> When a material is excited by a modulated light beam, the nonradiative deexcitation component generates heat, giving rise to a pressure wave propagating from the excitation region throughout the material. This pressure wave is the photoacoustic wave and follows the same modulation frequency as the illumination beam. The photoacoustic wave amplitude is proportional to the absorbed light converted into heat and can be detected by a microphone or a piezoelectric transducer. A chopper is used to modulate the incident beam and an oscilloscope or a lock-in amplifier is used to process the signal. This photoacoustic signal is therefore proportional to the laser power.

A common problem to all power meters based on the photoacoustic effect is their limitation to cover a very broad laser power-range from  $\mu\text{W}$  to  $\text{W}$ . The need to absorb the radiation in this range implies a saturation or degradation due to the direct incidence of a high-power laser beam. The main advantage of this type of meter is the flat response in wavelength, being limited only by the absorption spectral range of the absorbing material. This limitation was overcome in the present work by using a commercial neutral density filter as the absorbing material. Filters of different optical densities can be used, covering then a broad range of laser power; they present an extra advantage of not blocking the beam pathway. The neutral density filters are a cheap and reliable replacement for the carbon-black as a flat absorber in a very broad spectral region.

## 3 EXPERIMENTAL

The employed PA cell was designed and built at our facilities (Fig. 1). It is a free pathway photoacoustic cell made out of polished stainless steel, in a configuration where the neutral density filter acts as a window for the cell, with indirect detection of the PA signal. The volume of the cell is about  $60\text{ mm}^3$ . The detection element is a low-cost electret microphone with  $-65 \pm 4\text{ dB}$  sensitivity ( $0\text{ dB}$  ref.  $1\text{ V}/\mu\text{bar}$  at  $1\text{ kHz}$ ) and the

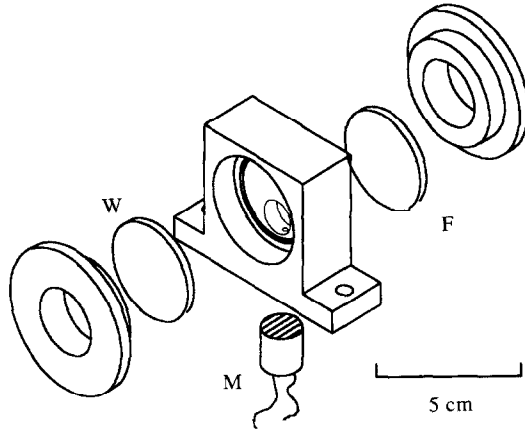

**Fig. 1.** Schematic drawing of the photoacoustic cell (M, microphone; F, filter; W, window).

modulation frequency chosen was 40 Hz, due to the better signal-to-noise ratio.

The neutral density filters employed are basically fused silica windows with a metallic film on one side, with optical densities varying from 0.04 to 1, supplied by Melles Griot (precision metallic neutral density filter set 03FSQO1 1).

#### 4 RESULTS AND DISCUSSION

The meter spectral response followed the optical absorption spectrum of the neutral density filters supplied by the manufacturer, for example, the 0.1 O.D. filter spectral response ranges from 300 to 2000 nm. The meter was calibrated for different optical densities filters using a commercial laser power-meter from Scientech Model 373 as the reference. The results obtained are shown on Table 1.

**TABLE 1**  
Sensitivity obtained and laser power-range covered using different O.D. filters

<i>Filter (O.D.)</i>	<i>Sensitivity (mV/W)</i>	<i>Power range (W)</i>
0.04	0.044	0.3->15
0.1	3.70	0.005-15
0.3	7.70	0.001-2
1.0	8.80	0.0005-2

When carbon-black was used as the absorbing material in the PA cell it was observed a 0.5 V/W sensitivity in the system.

The lower detection limit was defined as the signal for which the error in the measurement is 5%, once the measuring conditions are set (lock-in amplifier time constant of 1 s and modulation frequency of 40 Hz) and the upper limit was given by the maximum laser power with linear response from the meter; that is, the maximum power before filter degradation. The maximum laser power available at our laboratories was 15 W from a CW argon laser at 514.5 nm.

Due to its intrinsic characteristics this meter may also be used to measure the luminous power of lamps in spectroscopic purpose arrangements. The high detection threshold occurs because the neutral density filters are of the reflexive kind (small absorption of the beam) and also due to the high signal-to-noise ratio for the microphone.

#### ACKNOWLEDGEMENT

We acknowledge the Brazilian Agency CNPQ (Conselho Nacional de Desenvolvimento Científico e Tecnológico) for the financial support and for the scholarship for M. Duarte

#### REFERENCES

1. Shaw, R. W., Measuring pulse energies optoacoustically. *Laser Focus*, **17** (1981) 69–72.
2. Satheeshkumar, M. K. & Vallabhan, C. P. G., Use of a photoacoustic cell as a sensitive laser power meter. *J. Phys. E: Sci. Instrum.*, **8** (1985) 434–436.
3. Peralta, S. B., Al-Khafaji, H. H. & Williams, W., Photoacoustic optical power meter using piezoelectric detection. *J. Phys. E: Sci. Instrum.*, **21** (1988) 195–196.
4. Rai, V. N., Thakur, S. N. & Rai, D. K., A simple laser power meter dependent on photoacoustic effect. *J. Phys. E: Sci. Instrum.*, **20** (1987) 1472–1476.
5. Silva, M. D., Bandeira, I. N. & Miranda, L. C. M., Open-cell photoacoustic radiation detector. *J. Phys. E: Sci. Instrum.*, **20** (1987) 1476–1478.
6. Dyer, P. E., Bishop, M. & Tait, B. L., Laser energy absorption measurements using a differential joulemeter technique and application to optoacoustic cell calibration. *J. Phys. E: Sci. Instrum.*, **20** (1987) 82–84.
7. Radak, B. B. & Radak, B. B., A simple relative laser power meter. *Rev. Sci. Instrum.*, **62** (1991) 318–320.
8. Rosenwaig, A. & Gersho, A., Theory of the photoacoustic effect with solids. *J. Appl. Phys.*, **47** (1976) 64–69.