

MEASUREMENT OF THE ^{235}U ABSOLUTE ACTIVITY

Carmen C. Bueno and M. Damy S. Santos

Departamento de Física, Pontifícia Universidade Católica de São Paulo, Rua Marquês de Paranaguá, 111, 01303 São Paulo, SP, Brasil

Abstract

The absolute activity of ^{235}U contained in a sample was measured utilizing a sum-coincidence circuit which selects only the alpha particles emitted simultaneously with the 143 keV and 186 keV gamma radiations from the ^{231}Th (product nucleus).

The alpha particles were detected by means of a new type of a gas scintillating chamber, in which the light emitted by excitation of the gas atoms, due to the passage of a charged incoming particle, has its intensity increased by the action of an applied electric field. The gamma radiations were detected by means of a $1'' \times 1^{1/2}$ NaI(Tl) scintillation detector.

The value obtained for the half-life of ^{235}U , $(7.04 \pm 0.01) \times 10^8$ y, was compared with the data available from various observers which used different experimental techniques. It is shown that our results are in excellent agreement with the best data available on the subject.

Introduction

The absolute measurement of the activity of α - γ emitters whose decay schemes are simple is frequently measured by the method of coincidences whose advantages were emphasized by several observers⁽¹⁻³⁾. However, for radionuclides which show a complex disintegration scheme, the measurement of their absolute activity becomes very complicated owing to the necessity of correcting for several factors as well as to the inexistence of a generalized formula of this method for any radionuclide.

In this case, special care must be taken with the design of the detection system of the alpha and gamma radiations in order that the obtained data can be used with success.

With this purpose in mind, an alpha detector was built whose characteristics are more suitable for such measurements. This detector is constituted essentially by a gaseous scintillator, built in such a way that the number of photons produced by the alpha particle along its track is multiplied by the action of an electric field applied to its anode, operating either in the proportional region or in the region of the limited proportionality.

These photons are channeled through a light pipe to the window of a photo multiplier tube in order to obtain an electric pulse whose amplitude is proportional to the energy loss of the particle in the gaseous scintillator.

In our arrangement, the gamma radiation due to the ^{235}U (enriched at 19.99% in a sample of U_3O_8), was detected by means of a $1'' \times 1^{1/2}''$ NaI(Tl) of scintillator.

The precision obtained with this technique was checked comparing the measured ^{235}U half-life with the values obtained by various authors⁽⁶⁻¹⁰⁾ using different techniques; it is shown that our measurements agree, within the experimental error with the best measurement found in the literature.

Experimental method

In our measurements a source of uranium, enriched at $(19.99 \pm 0.01)\%$ in ^{235}U , as U_3O_8 was used; the source was obtained by the evaporation technique in high vacuum and deposited on a stainless steel disk of 20 mm of diameter.

The detection of alpha and gamma radiations was made using a gaseous proportional scintillator⁽¹¹⁻¹³⁾ counter and a $1 \times 1^{1/2}$ " NaI(Tl) scintillation counter, respectively. The U_3O_8 source was placed on this crystal in order to have the largest detection solid angle. The system, constituted by the source and the detector was shielded from the background radiation by blocks of lead 5 cm thick.

The alpha detector and its light guide, and the NaI(Tl) crystal were attached to RCA6342 photo-multiplier tubes with silicone grease in order to increase the light transmission. The photo multiplier tubes were directly connected to preamplifiers based on the AD509 operational amplifiers, in order to avoid the use of coaxial cables and to decrease the stray capacity of the anode in relation to ground and get the best signal to noise ratio. The pulses from the preamplifier were connected to the linear amplifiers and the gamma ray pulses were sent to a single channel analyzer, whose purpose was to select the gamma rays from ^{235}U and reject the pulses due to ^{238}U , ^{234}Th , etc. from the U_3O_8 source. By means of this procedure a selection of the gamma rays of interest from ^{235}U were selected and used in the coincidence line with the alpha pulses.

In order to obtain net pulses in the input coincidence analyzer, the pulses from both lines were normalized in order to obtain rectangular pulses of constant width and well defined amplitudes (we use different amplitudes for the alpha and gamma lines, for reasons which will be described later). Those pulses were sent to the base of a BC337 transistor used as emitter-follower, used as a sum-coincidence amplifier, in order to obtain pulses from the collector with final amplitude equal to the sum of the amplitudes of the alpha and gamma lines. Whenever the alpha and gamma pulses are separated by a time interval larger than the resolving time of the system, one obtains in the output independent pulses whose amplitudes are smaller than the sum of the two pulses and have an amplitude which is defined by the mono-stable CD4047 (which is used to normalize the pulses from alpha and gamma lines). The difference of amplitude of the three pulses are observed as three different lines, corresponding to three different channels numbers observed in the multi-channel analyzer (ORTEC model 6240). In this way, individual counts of the alpha, gamma and coincidences are simultaneously registered on the multi-channel analyzer. The block diagram is shown in Fig. 1.

Results

The energy spectrum of the gamma radiation from the U_3O_8 source obtained with a NaI(Tl) crystal is presented in Fig. 2. The peak at 92 keV is due to either ^{231}Th or ^{234}Th . The second and third peaks are due to gamma rays of 143 keV and 186 keV, respectively, from ^{231}Th . In the coincidence measurements we have used only the gamma rays from ^{231}Th in the energy range between 143 keV and 186 keV.

The energy spectrum of the alpha radiation from the U_3O_8 source obtained with the gaseous proportional scintillator is shown in Fig. 3. In this spectrum the alpha particles due ^{234}U , ^{235}U , ^{236}U and ^{238}U are shown: the energy⁽¹⁴⁻¹⁵⁾ of the alpha particles from those isotopes are very close to each other and therefore indistinguishable by the gaseous proportional scintillator. It follows that in the alpha line of the coincidence circuit the contributions from all the alpha particles of the above groups are present and a correcting factor for the alpha radiation of ^{235}U of interest, through a measurement of its radiation must be introduced.

Once those conditions were adjusted for the operation of the both alpha and gamma detectors, a measurement of the coincidences were taken using the system presented in Fig. 4. One should notice that it is necessary to provide a selection of the pulse amplitudes corresponding to the energies between 143 keV and 186 keV through the adjustment of the discriminator levels V_1 and V_2 ; in a similar way the discrimination level of the alpha particles should be adjusted to V_0 which corresponds to the discrimination between true alpha particles and the noise. The choice of V_0 , V_1 and V_2 was made through a measurement of the energy spectrum of gamma and alpha radiations from U_3O_8 source which are represented in Fig. 2 and Fig. 3, respectively.

The observation of these spectra shows that the channel which corresponds to the beginning of the alpha pulses, corresponding to V_0 , is the channel 32 and the gamma line the levels V_1 and V_2 are associated to the channels 26 and 60, respectively. It can be easily shown that with such adjustment a 10 V level corresponds to the 1024 channel.

he final results of the alpha-gamma coincidences from the U_3O_8 sample are shown in Fig. 5. The three observed lines are due to pulses from the alpha,

gamma and alpha-gamma coincidences: the individual alpha and gamma pulses are shown in the lines corresponding to 2,0 V and 4,8 V, respectively. When a coincidence occurs, a pulse of 6,8 V appears as a third line in the multi channel analyzer screen.

The obtained counting rates for the alpha (N_α), gamma (N_γ) and the genuine coincidences were:

$$N_\alpha = (174.79 \pm 0.02)$$

$$N_\gamma = (9.030 \pm 0.005)$$

$$N_{\alpha-\gamma} = (2.421 \pm 0.002)$$

Prior to the calculation of the absolute activity of the sample, a careful analysis was made of the influence of the error inherent to the method of coincidences, as well as of the possible systematic errors of the measurements.

Calculation of the absolute activity of the ^{235}U

The absolute activity due to the ^{235}U , contained in the U_3O_8 sample is given by:

$$- \frac{dN}{dt} = \frac{N_\alpha N_\gamma}{N_{\alpha\gamma}} \quad (1)$$

In our measurements the window of the gamma channel was adjusted to measure the gamma rays from the ^{231}Th in coincidence with the alpha particles from the ^{235}U ; the corresponding branching ratio⁽¹⁵⁾ was 80.78%. In this way only 80.78% of the α -particles from the ^{235}U are in genuine coincidence with the selected γ -rays. However there are γ -rays (1.61%) whose energies lay within the selected gamma energy window which can give rise to sum pulses which are not counted because those pulses are on the outside of the selected window. In this way the correction factor for the α -particles which are in coincidence will be (80.78 - 1.61)%.

On the other hand, sum of the detected γ -pulses (0.146%) are due to sums of γ -rays of smaller energies which when added could lie within the counting window giving rise to extra pulses. The correction factor for those pulses will be (100 - 0.146)%.

It follows unambiguously that the activity of the source is given by:

$$-\frac{dN}{dt} = (26.80 \pm 0.04) Bq \quad (2)$$

which represents the activity of the ^{235}U .

In order to check the precision of our measurements, the half-life of ^{235}U was calculated, taking into account the number of atoms of the ^{235}U present in the source of U_3O_8 (2.000 ± 0.004) mg. The obtained result was

$$T_{1/2} = (7.04 \pm 0.01) \times 10^8 \text{ y}$$

This value is better than that obtained by several previous measurements (see table 1) and agrees, within the experimental error, with the most accurate measurement of the ^{235}U half-life $(7.04 \pm 0.005) \times 10^8 \text{ y}$ due to Jaffey et al. (1971).

Table 1. Summary of the experimental determination of the ^{235}U

METHOD	$T_{1/2}(\times 10^8 \text{ y})$	AUTHOR
Mass Spectrometry	7.13 ± 0.15	Nier
Ionization Chamber	7.07 ± 0.33	Sayag
Specific Activity	7.13 ± 0.17	Fleming et al.
Ionization Chamber	6.84 ± 0.11	Würger and Mayer
Si Detector	6.92 ± 0.09	Deruytter et al.
Specific Activity	7.13 ± 0.09	White et al.
Specific Activity	7.04 ± 0.005	Jaffey et al.
Surface Barrier Det.	6.85 ± 0.09	Deruytter et al.
Absolute Activity	7.04 ± 0.01	This work

Conclusion

1) The measurement made with the sum-coincidence technique can be used for the measurement of the half-life of the ^{235}U with a precision comparable with the best data available in the literature.

2) The excellent agreement with the data shows that the scintillation proportional counter presents a high level of long term stability, comparable to the most sophisticated equipment used in the standardization of radionuclide absolute activities; its use is recommended due to the simplicity of its construction and operation.

3) The sum-coincidence circuit, designed for our experiments allows a simultaneous determination of all parameters involved in the measurements; it presents definite advantages for measurements with a high degree of accuracy for providing an independent check of all the essential systems whose data is used for the final computation of the results.

4) The enriched uranium sample used in our experiments was obtained from recycled fuel-elements (with 0.121% of ^{236}U). If the experiment were carried out with a sample of enriched natural uranium, the ^{236}U isotope would not be present and the measurement would be much easier.

5) Due to the high accuracy of the obtained results, one can conclude that the experimental system used can be used with advantage for the determination of the half-lives of alpha-gamma emitters, due to the excellent stability conditions of the counters and of the electronic circuits used, which were, in its great majority, designed and built in our laboratory.

References

1. P.J. Campion, J.G.V. Taylor and J.S. Merritt, Intern. J. of Appl. and Isot. **8**, 9 (1960).
2. A. Gandy, (1962) P.J. Campion, (1959), Intern. J. of Appl. Rad. and Isot. **4**, 232.???
3. de E. Roost, E. Funck and A. Spagnol, Intern. J. of Appl. and Isot. **20**, 387 (1969).
4. A.O. Nier, Phys. Rev. **55**, 150 (1939).
5. G. Sayag, Compt. Rend. **232**, 2091 (1951).
6. E.H.J. Fleming Jr., A. Ghiorso and B.B. Cunningham, Intern. J. of Appl. Rad. and Isot. **13**, 501 (1952).
7. E. Wurger and K.P. Meyer, Helv. Phys. Acta, **30**, 157 (1957).

8. A.J. Deruyter, I.G. Schroder and J.A. Moore, Nucl. Sci. Eng. **21**, 325 (1965).
9. A.H. Jaffey, K.F. Flynn, L.E. Glendenin, W.C. Bentley, and A.M. Essling, Phys. Rev. **C4**, 1889 (1971).
10. A.J. Deruytter and G.W. Penning, Phys. Rev. **C-10**, 383 (1974).
11. A.J.P.L. Policarpo, M.A.F. Alves and M. Salete, Nucl. Instrum. and Meth. **118**, 221 (1974).
12. H.J. Khoury, Um novo tipo de detector de partículas ionizantes. Ph.D. Thesis, Pontificia Universidade Católica de São Paulo, Brasil (1981).
13. A.J. Campos, IEEE Trans. Nucl. Sci. **31**, 133 (1984).
14. M.R. Schmorak, Nucl. Data Sheets, Academic Press Inc. N. Y., **36**, 387 (1982).
15. M.R. Schmorak, Nucl. Data Sheets, Academic Press Inc. N. Y., **40**, 8 (1983).

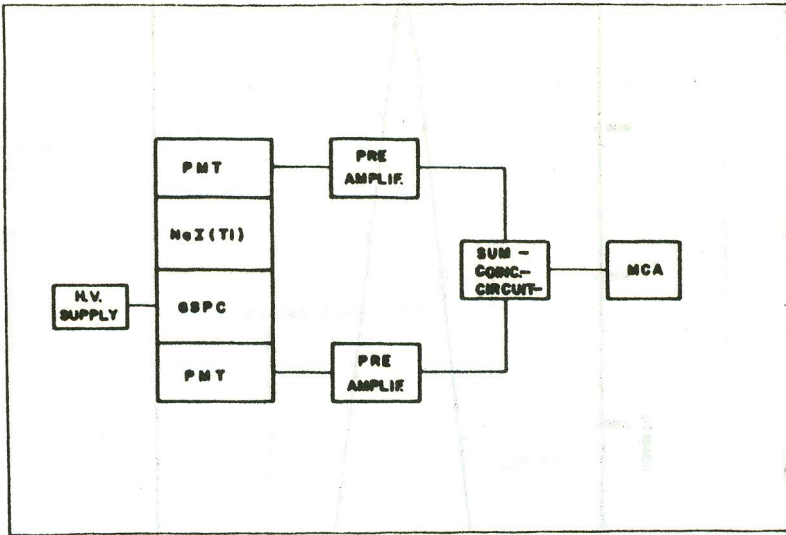

Fig. 1. Block diagram of the equipment used in this experiment.

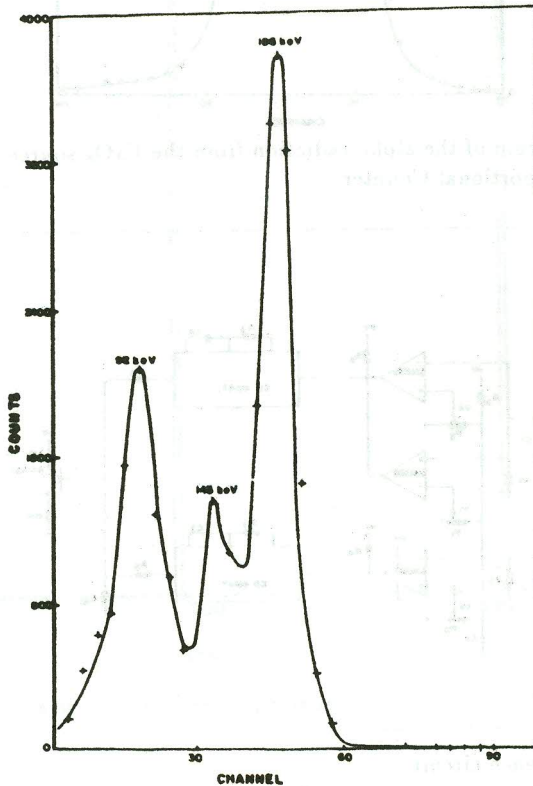

Fig. 2. Energy spectrum of the gamma radiation from the U_3O_8 source obtained with the NaI(Tl) detector.

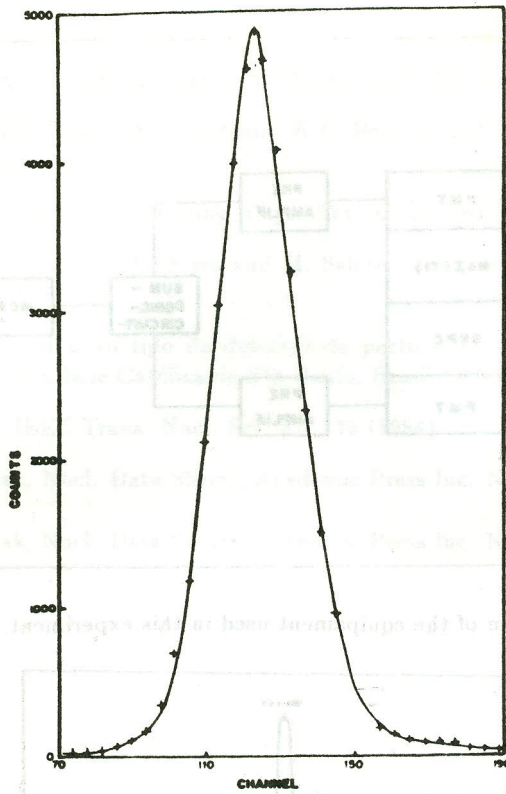

Fig. 3. Energy spectrum of the alpha radiation from the U_3O_8 source obtained with the Gas Scintillation Proportional Counter.

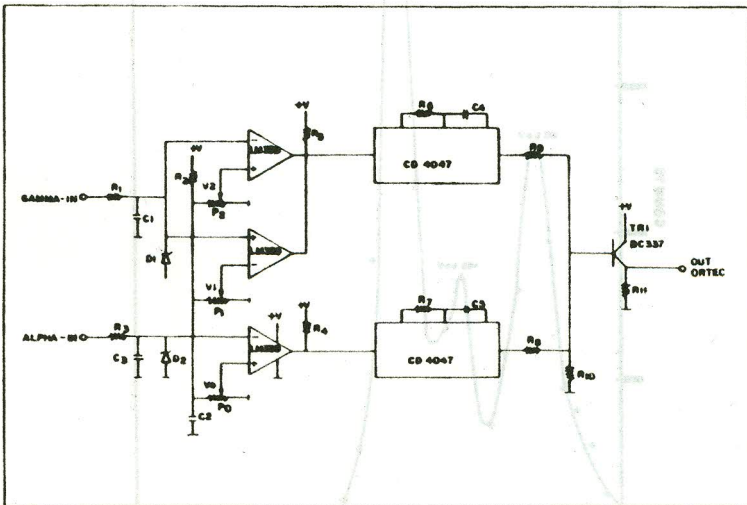

Fig. 4. Sum-coincidence circuit.

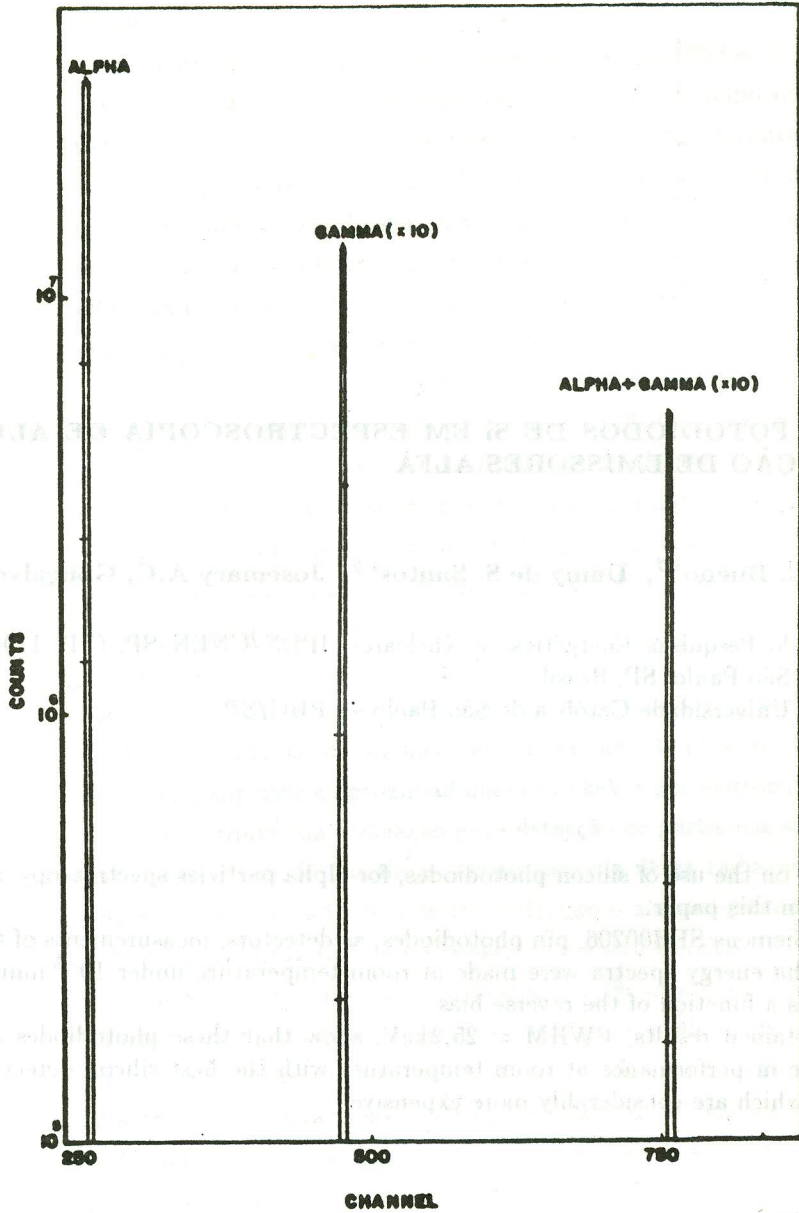

Fig. 5. Alpha-gamma sum-coincidence spectrum.